

EMEADS®

ZHEJIANG EMEADS TOOLS CO., LTD

伊米兹优质液压工具制造商



2023 CATALOG

www.emeads.com

EMEADS®

ZHEJIANG EMEADS TOOLS CO., LTD



ISO9001

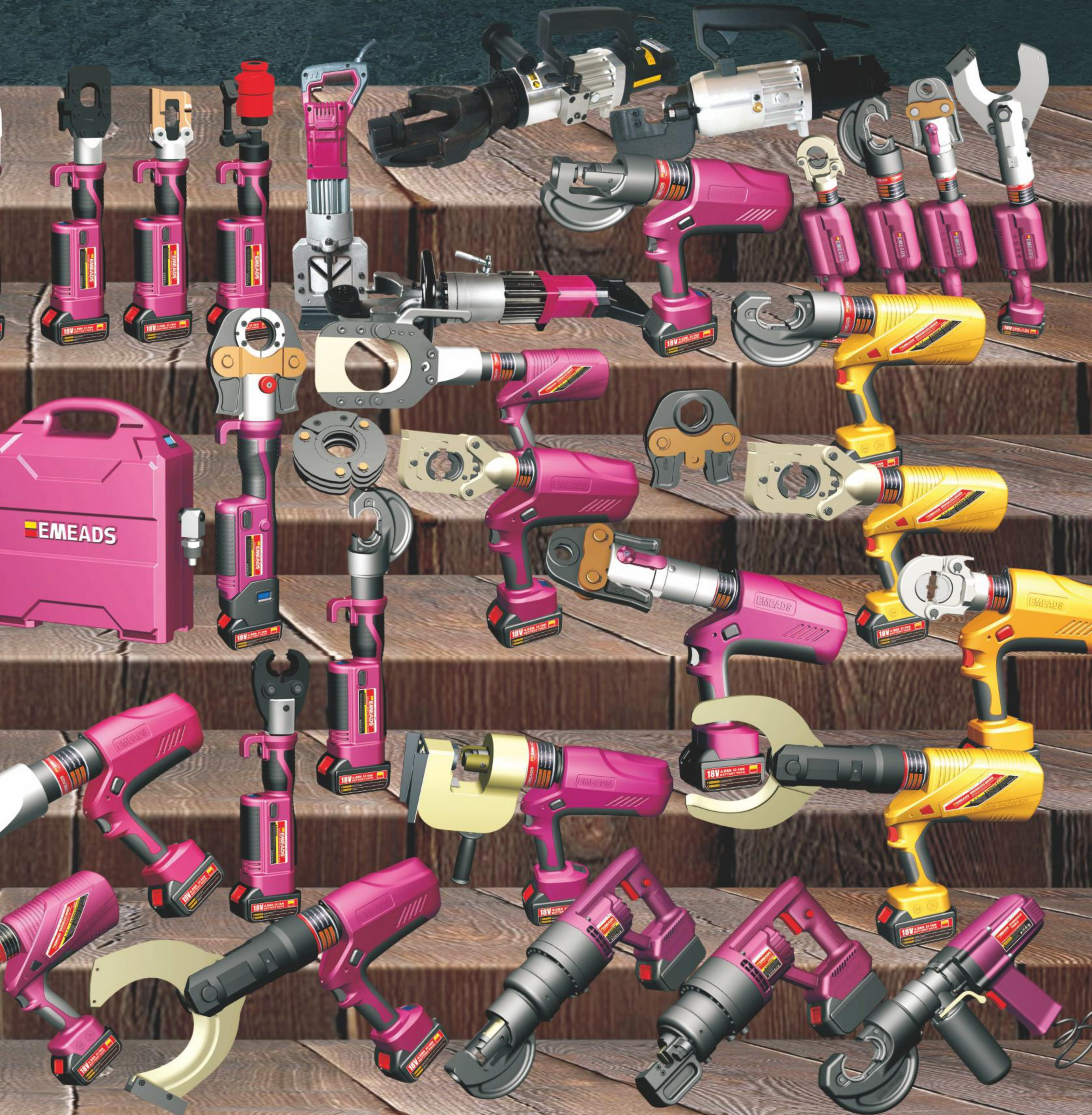

电力护航



电力抢修专用工具

EB- EMEADS630

售价

¥35800元

风雨同行



电力抢修专用工具

GES-EMEADS630

售价

¥33800元

公司简介

ABOUT US

浙江伊米兹工具有限公司是一家集设计、制造与销售为一体的高品质液压工具厂家。我们对卓越品质的不懈追求和生产管理的严格要求，确保EMEADS工具的每一件出库产品均能经得起严格测试。EMEADS致力于系统的发展创新应用解决方案，为电力、机械、铁路、建筑、船舶等领域提供高品质的产品和服务。



Zhejiang EMEADS Tools Co., Ltd. is a professional manufacturer on electrical tools. We design and manufacture of high quality hydraulic tools. Our unremitting pursuit of excellent quality and strict production management, making the EMEADS tools ensure that each piece of outbound products can stand up to rigorous testing. We are committed to the development of the system innovation application solutions. EMEADS provides high-quality products and services for the electric power, machinery, railway, construction, shipbuilding and other fields.



设备展示

EQUIPMENT



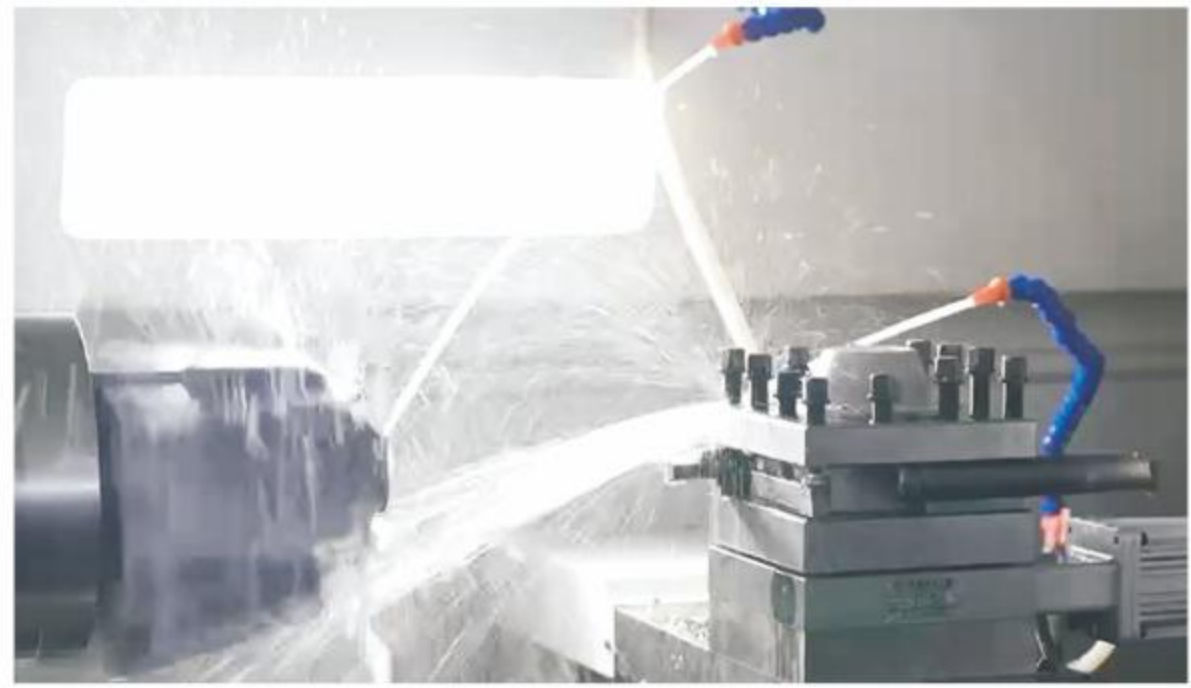
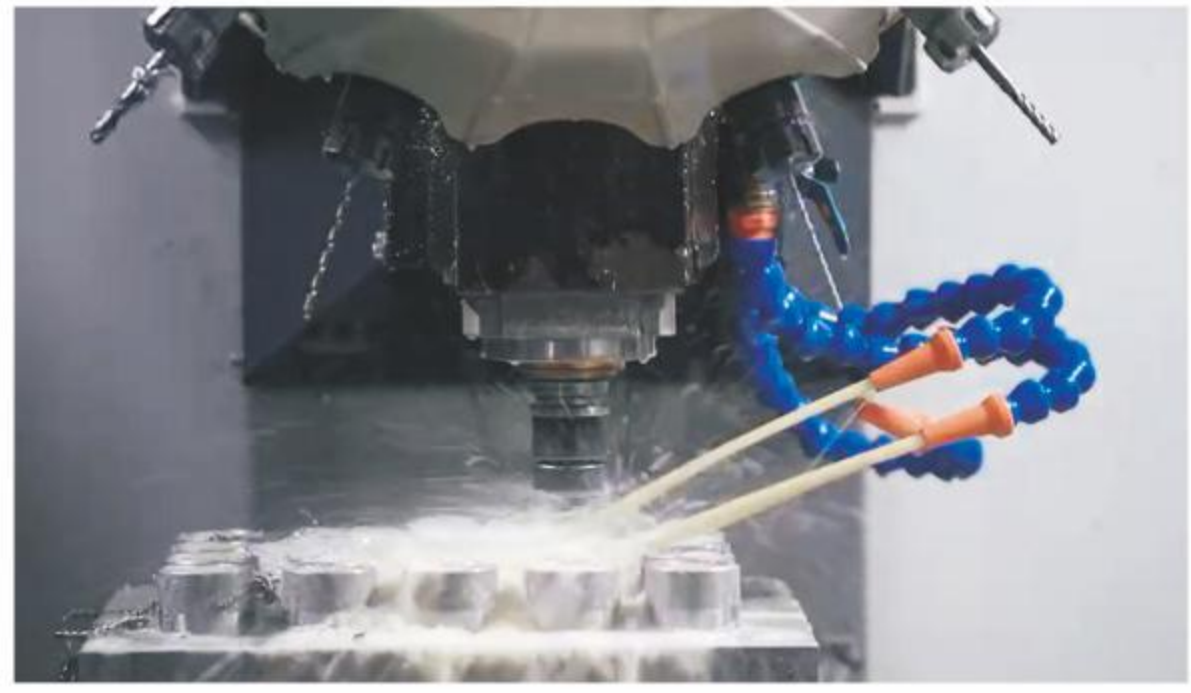



**EMEADS hydraulic tool technology
innovation enterprise**





资质证书

QUALIFICATIONS

Scientific research and
technology patent units

Bearing China's engineering equipment
industry important appliance!



CERTIFICATE

ATTESTATION CERTIFICATE OF MACHINERY AND ELECTROMAGNETIC COMPATIBILITY DIRECTIVES

Technical file of the company mentioned below has been observed
2006/42/EC Machinery Directive and 2014/30/EU Electromagnetic Compatibility Directive
have been taken as references for these processes

Company Name : Zhejiang EMEADS Tools Co., Ltd.
Company Address : Lupu Pharmaceutical Packaging Industrial Park, Yuhuan
District, Taizhou City, Zhejiang Province, China
Related Directives and Annex : 2006/42/EC Machinery Directive
2014/30/EU Electromagnetic Compatibility Directive
Related Standards : EN 62841-1:2015; EN 55014-1:2017; EN 55014-2:2015
EN 61000-3-2:2019; EN 61000-3-3:2013+A1:2019
Product Name : Lithium electric hydraulic pliers
Report No and Date : TCF2292A1103598
Product Brand/Model/Type : EB-400,EB-300,EB-300B,EB-400U,EB-400B,EB-630,EB-40,EB-55,
EB-65,EB-65C,EB-85,EB-85C,EB-105,EB-105C,EB-120,EB-120C,
EB-135,EB-135C,EB-1125H,EB-1220H,EB-10,EB-16,EB-20,EB-2432,
EB-2436,EB-1532,EB-1632,EB-1550,EB-1525,EB-65100,EBS-400,
EBS-300,EBS-300B,EBS-400U,EBS-400B,EBS-630,EBS-40,EBS-55,
EBS-65,EBS-65C,EBS-85,EBS-85C,EBS-105,EBS-105C,EBS-120,
EBS-120C,EBS-135,EBS-135C,EBS-1125H,EBS-1220H,EBS-10,EBS-16,
EBS-20,EBS-2432,EBS-2436,EBS-1532,EBS-1632,EBS-1550,EBS-1525,
EBS-65100,ES-300,ES-400B,ES-240,ES-32C,ES-50

Certificate Number : M.2021.206.C68770
Initial Assessment Date : 04.11.2021
Registration Date : 05.11.2021
Reissue Date/No : -
Expiry Date : 04.11.2026

UDEM International Certification
Auditing Training Centre Industry
and Trade Inc.Co.

The validity of the certificate can be checked through www.udemtd.com.tr. The CE mark shown on the right
can only be used under the responsibility of the manufacturer with the completion of EC Declaration of
Conformity for all the relevant Directives. This certificate remains the property of UDEM International Certification
Auditing Training Centre Industry and Trade Co. Ltd. to whom it must be returned upon request. The above
named firm must keep a copy of this certificate for 15 years from the registration of certificate. This certificate
only covers the product(s) stated above and UDEM must be noticed in case of any changes on the product(s)

Address: Mutlukent Mahallesi 2073 Sokak (Eski 93 Sokak) No:10 Çankaya - Ankara - TURKEY
Phone: +90 0312 443 03 90 Fax: +90 0312 443 03 76
E-mail: info@udemtd.com.tr www.udem.com.tr





CONTENTS 产品目录

电力工具

压接系列

01-23

- 充电式液压压接工具
- 经济型液压工具
- 插电式液压工具
- 手动式液压压接工具
- 分体式压接头部

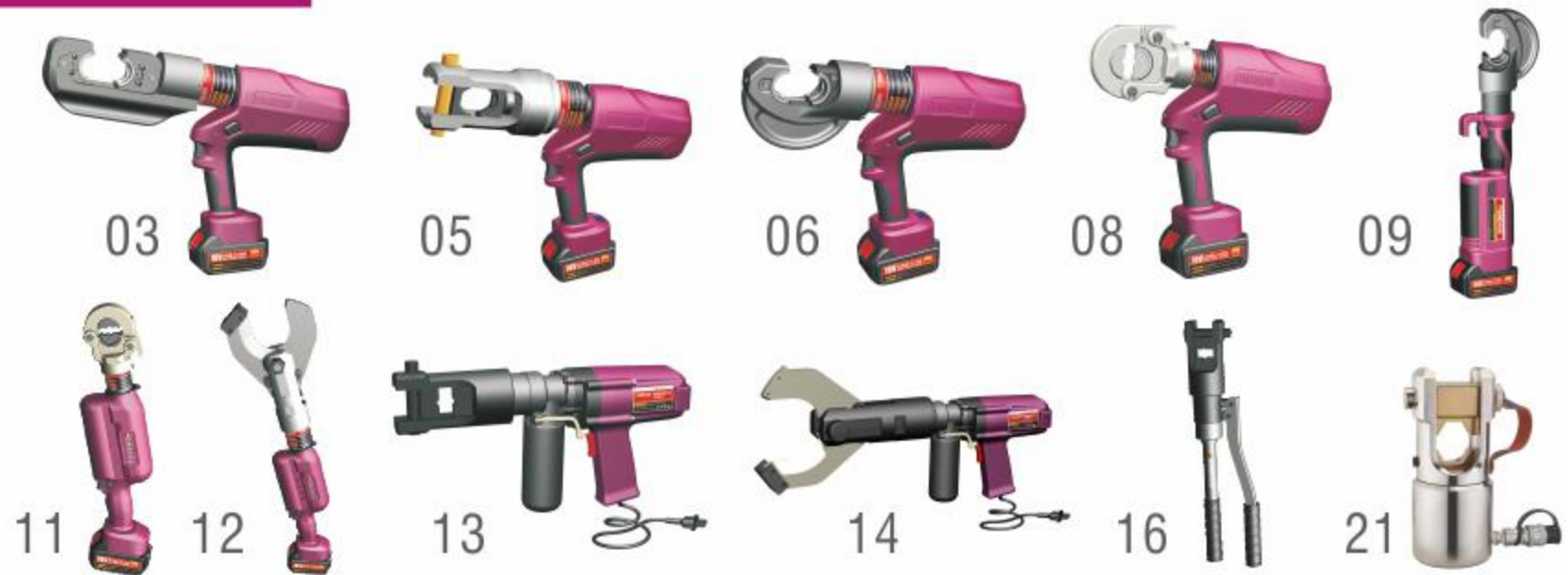

剪刀系列

24-58

- 充电式液压线缆剪
- 充电式液压铁管专用剪刀
- 手动式液压线缆剪
- 分体式剪刀头部



多功能系列

59-62

- 充电式多功能液压工具
- 手动式多功能液压工具
- 多功能选配钳头



管件系列

63-118

- 充电式液压卡压工具
- 分体式液压卡压工具
- 充电式电动液压泵
- 经济型充电式液压卡压工具
- 充电式液压滑套滑紧工具
- 手动式液压滑紧工具
- 手动式液压管件工具
- 卡压式管件承口的结构和尺寸



管件工具

消防救援系列 119-145

- 充电式液压切断机
- 中型电动液压破拆工具组
- 高效移动电源版工具组
- 轻型液压破拆救援工具组
- 中型液压破拆救援工具组
- 重型液压破拆救援工具组
- 升级版两栖套件
- 混凝土液压破拆工具组
- 手动破拆救援工具组
- 破拆切割锯系列
- 其他救援配套产品



螺母破开系列 146-151

- 充电式液压螺母破开工具
- 手动式液压螺母破开工具



开孔系列 152-158

- 充电式液压开孔工具
- 打孔冲头
- 手动式液压开孔工具



液压泵/母排加工机系列 159-170

- 液压泵
- 液压母排加工机



基建系列 171-178

- 充电式液压冲孔机
- 充电式液压钢筋剪
- 插电式钢筋切断机
- 插电式钢筋弯曲机



拉马/千斤顶系列 179-188

- 液压拉马
- 千斤顶



CRIMPING SERIES

压接系列

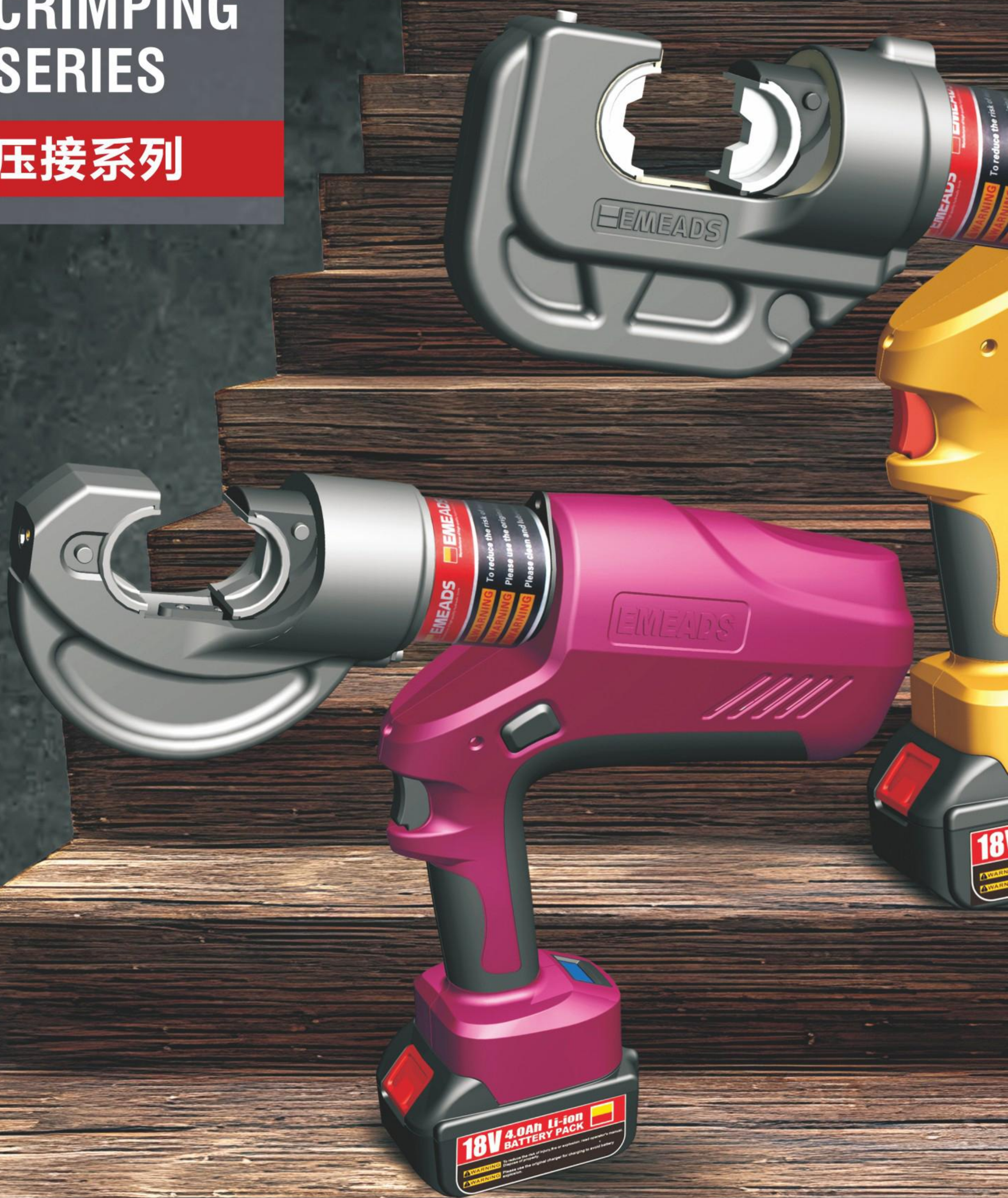

连续压接 高效作业

 **EMEADS**[®]
ZHEJIANG EMEADS TOOLS CO., LTD

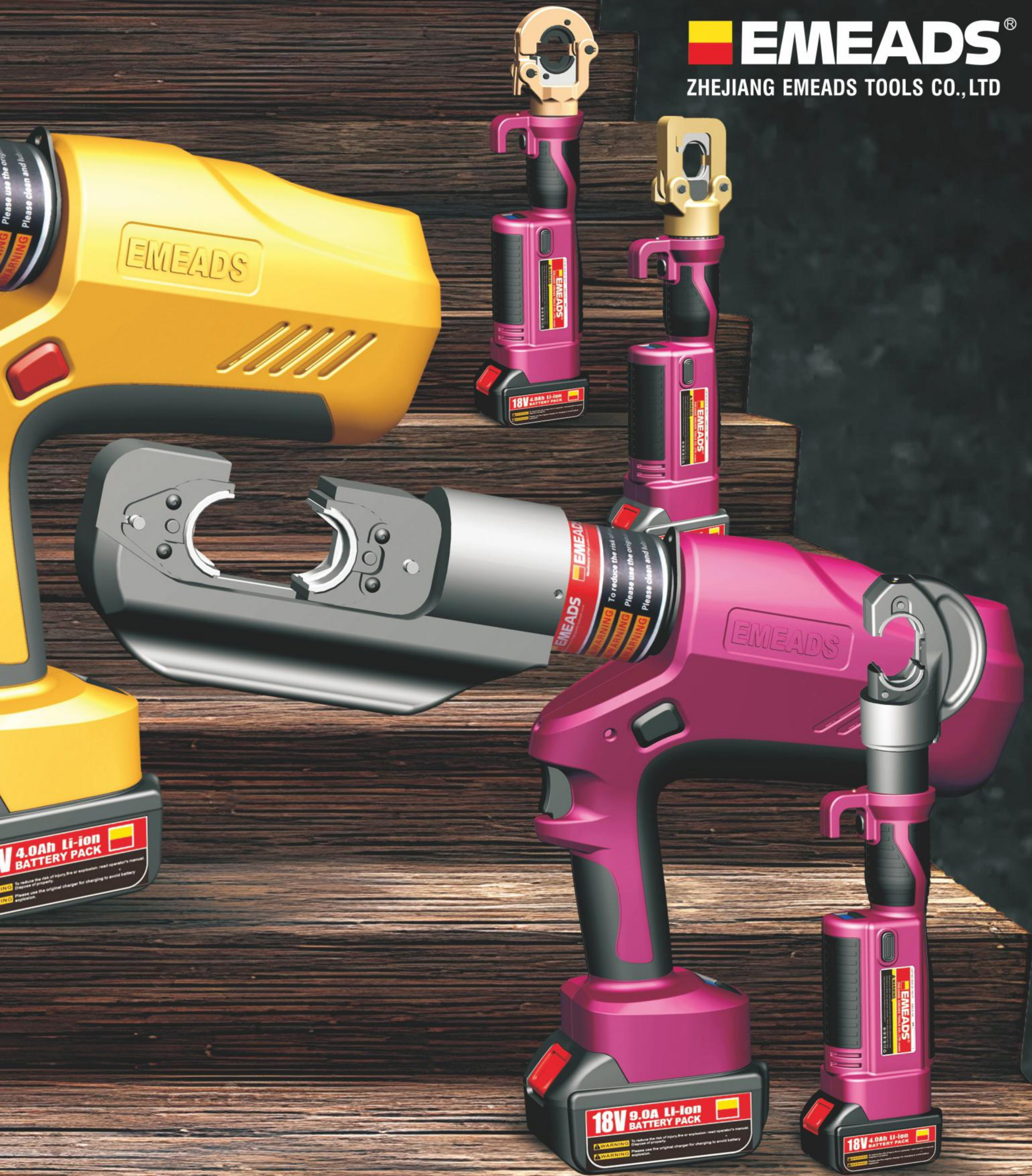

CONTINUOUS CRIMPING
EFFICIENT OPERATION

EMEADS630 CHARGING TYPE HYDRAULIC CRIMPING TOOLS

EB-EMEADS630



技术参数 / TECHNICAL DATA

压接力 Crimping force:	150KN
行程 Stroke:	50mm
压接次数 Crimping times:	300times (Cu150mm ²) (饱和电压 Per saturation voltage)
压接周期 Crimping cycle:	6-18s 取决于电缆的尺寸 Depend on the size of cable
电池电压/容量 Voltage/capacity:	18V/9.0Ah
充电器电压 Charger voltage:	100-240VAC
剪切范围 Cutting range:	剪切导线、钢芯铝绞线、钢芯电缆、铜铝电缆导线 Shear conductor, steel core aluminum strand, steel core cable, copper aluminum cable conductor
净重 Net weight:	8kg
充电时间 Charging time:	4 hours
包装 Package:	塑料盒 Plastic box
配件 ACCESSORIES	
压接模具 Crimping dies:	4,6,10,16,25,35,50,70,95,120,150,185,240,300,400,500,630mm ²
电池 Battery:	2pcs
充电器 Charger:	1pc

GES-EMEADS630



技术参数 / TECHNICAL DATA

压接力 Crimping force:	150KN
行程 Stroke:	50mm
压接次数 Crimping times:	300times (Cu150mm ²) (饱和电压 Per saturation voltage)
压接周期 Crimping cycle:	6-18s 取决于电缆的尺寸 Depend on the size of cable
充电器电压 Charger voltage:	100-240VAC
电池电压/容量 Voltage/capacity:	18V/9.0Ah
剪切范围 Cutting range:	剪切导线、钢芯铝绞线、钢芯电缆、铜铝电缆导线 Shear conductor, steel core aluminum strand, steel core cable, copper aluminum cable conductor
净重 Net weight:	7kg
充电时间 Charging time:	4 hours
包装 Package:	塑料盒 Plastic box
配件 ACCESSORIES	
压接模具 Crimping dies:	4,6,10,16,25,35,50,70,95,120,150,185,240,300,400,500,630mm ²
电池 Battery:	2pcs
充电器 Charger:	1pc

工具特点

EB-EMEADS630、GES-EMEADS630具有良好的施工性能，压接铜导线4-630平方端子、铝端子6-500平方，剪切钢芯铝绞线240平方、钢芯电缆300平方以下，单芯铜铝电缆400平方以下，超长的待机时间，防水设计的电池包、防水设计主控电路，马达可在暴风雨中完成抢修使命，长达5年的质保时间，为电力系统保驾护航，风雨同行！

工具操作功能

- 微电脑控制系统，压接时自动检测压力，双重安全保护。
- 该工具配备了双活塞泵，其特点是快速处理连接材料并转移到缓慢的压接会自动使系统处于高压状态。如果识别出与设定的工作压力有偏差或电池电量不足，则会发出声音信号并闪烁红色显示。
- 一键控制，按下触发按钮开始工作，松开一半触发装置停止施加压力，按压回油开关将活塞退回至原始位置。
- 温度传感器使工具自动停止工作，当长时间工作温度超过60°C时，故障信号响起，这意味着工具必须等到温度降至正常水平才能继续工作。
- 一键控制连续使用功能——**功能1**：按下触发器开始工作，松开触发器意味着停止加压，继续增加压力，直到跳压活塞返回初始位置。**功能2**：按下触发器开始工作，松开触发器意味着停止加压，继续加大压力跳压活塞回位，按下引发活塞回到停止，继续按下开关机进入新的加压工作。**功能3**：按下扳机开始工作，松开扳机表示停止加压，继续加压压力上升后跳按扳机后停止后退，继续按压扳机后跳不放扳机活塞自动停止后回到最后一个停止位，可选择任意大小位置两次在未放扳机自动停止位置选择。

FEATURES

EB-EMEADS630 and GES-EMEADS630 have good construction performance, crimping 4-630 square terminals of copper conductors, 6-500 square terminals of aluminum, shearing 240 square meters of steel cored aluminum strands, less than 300 square meters of steel cored cables, single core copper aluminum cables, less than 400 square meters, extra long standby time, waterproof battery packs, waterproof design master control circuits, motors can complete the mission of emergency repair in the storm, with a warranty period of up to five years to escort the power system, Come with wind and rain!

OPERATION FUNCTION

- Micro computer control system-automatically detect the pressure when it is crimping, with double safety protect.
- The tool equipped with a double piston pump which characterized by a fast approach towards the connecting material and transfer to high pressure automatically by slow crimping. If a deviation from the set operation pressure or low battery charges is identified, an acoustic signal sounds and a red display flashes.
- One key control- press the trigger to start working, half loosening the trigger means stop forcing pressure, loosening fully means piston Return to the original position.
- A Temperature sensor makes the tool stop working automatically. When the temperature over 60°C under long time working, the fault signal sounds, it means the tool can't continue work until the temperature reduced to the normal.
- One-key control of continuous use function - Function 1: press the trigger to start working, release the trigger means to stop pressurizing, continue to increase the pressure until the jump pressure piston returns to the initial position. Function 2: Press the trigger to start working, release the trigger means to stop pressurizing, continue to increase the pressure to jump pressure piston back, press the trigger piston back to stop, continue to press the switch machine into a new pressing work. Function 3: press the trigger to start working, loosen the trigger said stop pressure, continue to pressure the pressure rise to jump after pressing back press the trigger to stop back, continue to press the trigger to jump after the pressure not to put the trigger piston automatically stop after back to the last stop bit, can choose any size position twice in the case of not to put the trigger automatically stop location choice.

压接工具DES-630A压接要求

序号	铜接线端子型号	总长 (mm)	剥线长度 (mm)	剥线长度偏差 (mm)	压接模具	压接次数	压接宽度 (mm)	最大压接高度N值 (mm)
1	DT16-6	55	31	+3, +5	CU16	2	12	7.6±0.38
2	DT25-6	60	34	+3, +5	CU25	2	12	8.5±0.425
3	DT35-10	66	36	+3, +5	CU35	2	12	10.2±0.51
4	DT50-10	72	40	+3, +5	CU50	2	12	11.8±0.59
5	DT70-12	80	42	+3, +5	CU70	2	12	13.2±0.66
6	DT95-12	87	46	+3, +5	CU95	2	12	15.5±0.775
7	DT120-14	96	48	+3, +5	CU120	2	12	16.7±0.835
8	DT150-14	103	52	+3, +5	CU150	3	12	19±0.95
9	DT185-16	115	55	+3, +5	CU185	3	12	21.5±1.075
10	DT240-16	120	60	+3, +5	CU240	3	12	23.2±1.16
11	DT300-16	135	65	+3, +5	CU300	3	12	26.7±1.335
12	DT400-16	150	70	+3, +5	CU400	3	12	29.3±1.465

备注：可选型号有EBS、EB、DES、DE

630 CHARGING TYPE HYDRAULIC CRIMPING TOOLS

EBS-630



连续压接功能型
With continuous function

EB-630



常规功能型
Regular function

DES-630 (无刷驱动)



连续压接功能型
With continuous function

DE-630 (无刷驱动)



常规功能型
Regular function

技术参数 / TECHNICAL DATA

压接力 Crimping force:	200KN
行程 Stroke:	20mm
压接次数 Crimping times:	120times(Cu150mm ²) (饱和电压 Per saturation voltage)
压接周期 Crimping cycle:	6-18s 取决于电缆的尺寸 Depend on the size of cable
充电器电压 Charger voltage:	100-240VAC
电池电压/容量 Voltage/capacity:	18V/4.0Ah
净重 Net weight:	7kg
充电时间 Charging time:	2 hours
包装 Package:	塑料盒 Plastic box
配件 ACCESSORIES	
压接模具 Crimping dies:	25,35,50,70,95,120,150,185,240,300,400,500,630mm ²
电池 Battery:	2pcs
充电器 Charger:	1pc



400B CHARGING TYPE HYDRAULIC CRIMPING TOOLS

EBS-400B



连续压接功能型
With continuous function

EB-400B



常规功能型
Regular function

DES-400B (无刷驱动)



连续压接功能型
With continuous function

DE-400B (无刷驱动)



常规功能型
Regular function

技术参数 / TECHNICAL DATA

压接力 Crimping force:	120KN
行程 Stroke:	35mm
压接次数 Crimping times:	120times(Cu150mm ²) (饱和电压 Per saturation voltage)
压接周期 Crimping cycle:	6-18s 取决于电缆的尺寸 Depend on the size of cable
剪切功能 Cut function:	单芯铜铝电缆400mm ²
充电器电压 Charger voltage:	100-240VAC
电池电压/容量 Voltage/capacity:	18V/4.0Ah
净重 Net weight:	6.2kg
充电时间 Charging time:	2 hours
包装 Package:	塑料盒 Plastic box

配件 ACCESSORIES

压接模具 Crimping dies:	4,6,10,16,25,35,50,70,95,120,150,185,240,300,400mm ²
电池 Battery:	2pcs
充电器 Charger:	1pc



400 CHARGING TYPE HYDRAULIC CRIMPING TOOLS

EBS-400



连续压接功能型
With continuous function

EB-400



常规功能型
Regular function

DES-400 (无刷驱动)



连续压接功能型
With continuous function

DE-400 (无刷驱动)



常规功能型
Regular function

技术参数 / TECHNICAL DATA

压接力 Crimping force:	120KN
行程 Stroke:	42mm
压接次数 Crimping times:	120times (Cu150mm ²) (饱和电压 Per saturation voltage)
压接周期 Crimping cycle:	6-18s 取决于电缆的尺寸 Depend on the size of cable
剪切功能 Cut function:	单芯铜铝电缆400mm ²
充电器电压 Charger voltage:	100-240VAC
电池电压/容量 Voltage/capacity:	18V/4.0Ah
净重 Net weight:	7.5kg
充电时间 Charging time:	2 hours
包装 Package:	塑料盒 Plastic box

配件 ACCESSORIES

压接模具 Crimping dies:	4,6,10,16,25,35,50,70,95,120,150,185,240,300,400mm ²
电池 Battery:	2pcs
充电器 Charger:	1pc



300 CHARGING TYPE HYDRAULIC CRIMPING TOOLS

EBS-300



连续压接功能型
With continuous function

EB-300



常规功能型
Regular function

DES-300 (无刷驱动)



连续压接功能型
With continuous function

DE-300 (无刷驱动)



常规功能型
Regular function

技术参数 / TECHNICAL DATA	
压接力 Crimping force:	60KN
行程 Stroke:	17mm
压接次数 Crimping times:	120times (Cu150mm ²) (饱和电压 Per saturation voltage)
压接周期 Crimping cycle:	6-18s 取决于电缆的尺寸 Depend on the size of cable
充电器电压 Charger voltage:	100-240VAC
电池电压/容量 Voltage/capacity:	18V/4.0Ah
净重 Net weight:	6.4kg
充电时间 Charging time:	2 hours
包装 Package:	塑料盒 Plastic box
配件 ACCESSORIES	
压接模具 Crimping dies:	4,6,10,16,25,35,50,70,95,120,150,185,240,300mm ²
电池 Battery:	2pcs
充电器 Charger:	1pc



MINI CHARGING TYPE HYDRAULIC CRIMPING TOOLS

GES-400B / GE-400B (带连续压接功能) (可选有刷或无刷)

技术参数 / TECHNICAL DATA	GES-400B / GE-400B
压接力 Crimping force:	120KN
行程 Stroke:	35mm
压接次数 Crimping times:	120times(Cu150mm ²) (饱和电压 Per saturation voltage)
压接周期 Crimping cycle:	7-10s 取决于电缆的尺寸 Depend on the size of cable
剪切功能 Cut function:	单芯铜铝电缆400mm ²
电池电压/容量 Voltage/capacity:	18V/4.0Ah
净重 Net weight:	3.5kg
充电时间 Charging time:	2 hours
包装 Package:	塑料盒 Plastic box
配件 ACCESSORIES	
压接模具 Crimping dies:	4,6,10,16,25,35,50,70,95,120,150,185,240,300,400mm ²
电池 Battery:	2pcs
充电器 Charger:	1pc



GES-300 / GE-300 (可选常规款或连续压接功能款) (可选有刷或无刷)

技术参数 / TECHNICAL DATA	GES-300 / GE-300
压接力 Crimping force:	60KN
行程 Stroke:	17mm
压接次数 Crimping times:	300times(Cu150mm ²) (饱和电压 Per saturation voltage)
压接周期 Crimping cycle:	5-8s 取决于电缆的尺寸 Depend on the size of cable
电池电压/容量 Voltage/capacity:	18V/4.0Ah
净重 Net weight:	3.5kg
充电时间 Charging time:	2 hours
包装 Package:	塑料盒 Plastic box
配件 ACCESSORIES	
压接模具 Crimping dies:	4,6,10,16,25,35,50,70,95,120,150,185,240,300mm ²
电池 Battery:	2pcs
充电器 Charger:	1pc



GES-240 (可选有刷或无刷)

技术参数 / TECHNICAL DATA	GES-240
压接力 Crimping force:	60KN
行程 Stroke:	16mm
压接次数 Crimping times:	170times(Cu150mm ²) (饱和电压 Per saturation voltage)
压接周期 Crimping cycle:	3-6s 取决于电缆的尺寸 Depend on the size of cable
剪切功能 Cut function:	剪切钢芯导线20mm、铜铝导线240平方
电池电压/容量 Voltage/capacity:	18V/4.0Ah
净重 Net weight:	3.1kg
充电时间 Charging time:	2 hours
包装 Package:	塑料盒 Plastic box
配件 ACCESSORIES	
压接模具 Crimping dies:	10,16,25,35,50,70,95,120,150,185,240mm ²
电池 Battery:	2pcs
充电器 Charger:	1pc



GES-300C / GE-300C

技术参数 / TECHNICAL DATA	GES-300C / GE-300C
压接力 Crimping force:	60KN
行程 Stroke:	17mm
压接次数 Crimping times:	170times(Cu150mm ²) (饱和电压 Per saturation voltage)
压接物 Crimping items	SC、UT、OT、SV、GT端子
压接周期 Crimping cycle:	3-6s 取决于电缆的尺寸 Depend on the size of cable
电池电压/容量 Voltage/capacity:	18V/4.0Ah
净重 Net weight:	3.5kg
充电时间 Charging time:	2 hours
包装 Package:	塑料盒 Plastic box
配件 ACCESSORIES	
压接模具 Crimping dies:	16,25,35,50,70,95,120,150,185,240mm ² (剪切25mm以下电缆)
电池 Battery:	2pcs
充电器 Charger:	1pc



GES-300C-2 / GE-300C-2 (压接+剪切多功能)

技术参数 / TECHNICAL DATA	GES-300C-2 / GE-300C-2
剪切力 Cutting force:	60KN
行程 Stroke:	17mm
剪切次数 Cutting times:	130times (饱和电压 Per saturation voltage)
剪切范围 Cutting range:	Φ30mm _{max} 铜/铝和铠装电缆 Armoured and Cu/Al cable
压接范围 Crimping range:	4-300mm ²
电池电压/容量 Voltage/capacity:	18V/4.0Ah
净重 Net weight:	3.0kg
充电时间 Charging time:	2 hours
包装 Package:	塑料盒 Plastic box
配件 ACCESSORIES	
电池 Battery:	2pcs
充电器 Charger:	1pc



GES-300B / GES-30J

技术参数 / TECHNICAL DATA	GES-300B	GES-30J
压接力 Crimping force:	60KN	50KN
行程 Stroke:	17mm	33mm
压接次数 Crimping times:	300times(Cu150mm ²) (饱和电压 Per saturation voltage)	170times(Cu150mm ²) (饱和电压 Per saturation voltage)
压接周期 Crimping cycle:	5-8s 取决于电缆的尺寸 Depend on the size of cable	3-6s 取决于电缆的尺寸 Depend on the size of cable
电池电压/容量 Voltage/capacity:	18V/4.0Ah	18V/4.0Ah
净重 Net weight:	4kg	4kg
充电时间 Charging time:	2 hours	2 hours
包装 Package:	塑料盒 Plastic box	塑料盒 Plastic box
配件 ACCESSORIES		
压接模具 Crimping dies:	4,6,10,16,25,35,50,70,95, 120,150,185,240,300mm ²	标配16副 16 pairs as standard
电池 Battery:	2pcs	2pcs
充电器 Charger:	1pc	1pc



CHARGING TYPE ECONOMICAL HYDRAULIC TOOLS

EA-300 经济型液压压接工具



技术参数 / TECHNICAL DATA

压接力 Crimping force:	60KN
行程 Stroke:	17mm
压接次数 Crimping times:	120times(Cu150mm ²) (饱和电压 Per saturation voltage)
压接周期 Crimping cycle:	6-18s 取决于电缆的尺寸 Depend on the size of cable
充电器电压 Charger voltage:	100-240VAC
电池电压/容量 Voltage/capacity:	18V/4.0Ah
净重Net weight:	4.5kg
充电时间 Charging time:	2 hours
包装 Package:	塑料盒 Plastic box

配件 ACCESSORIES

压接模具 Crimping dies:	16,25,35,50,70,95,120,150,185,240,300mm ²
电池 Battery:	2pcs
充电器 Charger:	1pc

EA-300H 经济型液压压接工具



技术参数 / TECHNICAL DATA

压接力 Crimping force:	60KN
行程 Stroke:	17mm
压接次数 Crimping times:	120times(Cu150mm ²) (饱和电压 Per saturation voltage)
压接周期 Crimping cycle:	6-18s 取决于电缆的尺寸 Depend on the size of cable
充电器电压 Charger voltage:	100-240VAC
电池电压/容量 Voltage/capacity:	18V/4.0Ah
净重Net weight:	4.5kg
充电时间 Charging time:	2 hours
包装 Package:	塑料盒 Plastic box

配件 ACCESSORIES

压接模具 Crimping dies:	10,16,25,35,50,70,95,120,150,185,240,300mm ²
电池 Battery:	2pcs
充电器 Charger:	1pc

EA-300B 经济型液压压接工具



技术参数 / TECHNICAL DATA

压接力 Crimping force:	60KN
行程 Stroke:	33mm
压接次数 Crimping times:	120times(Cu150mm ²) (饱和电压 Per saturation voltage)
压接周期 Crimping cycle:	6-18s 取决于电缆的尺寸 Depend on the size of cable
充电器电压 Charger voltage:	100-240VAC
电池电压/容量 Voltage/capacity:	18V/4.0Ah
净重Net weight:	4.5kg
充电时间 Charging time:	2 hours
包装 Package:	塑料盒 Plastic box

配件 ACCESSORIES

压接模具 Crimping dies:	16,25,35,50,70,95,120,150,185,240,300mm ²
电池 Battery:	2pcs
充电器 Charger:	1pc

EA-400B 经济型液压压接工具



技术参数 / TECHNICAL DATA

压接力 Crimping force:	120KN
行程 Stroke:	35mm
压接次数 Crimping times:	120times(Cu150mm ²) (饱和电压 Per saturation voltage)
压接周期 Crimping cycle:	6-18s 取决于电缆的尺寸 Depend on the size of cable
充电器电压 Charger voltage:	100-240VAC
电池电压/容量 Voltage/capacity:	18V/4.0Ah
净重Net weight:	7kg
充电时间 Charging time:	2 hours
包装 Package:	塑料盒 Plastic box

配件 ACCESSORIES

压接模具 Crimping dies:	16,25,35,50,70,95,120,150,185,240,300,400mm ²
电池 Battery:	2pcs
充电器 Charger:	1pc

CHARGING TYPE ECONOMICAL HYDRAULIC TOOLS

EA-85C 经济型液压剪切工具

技术参数 / TECHNICAL DATA

剪切力 Cutting force:	120KN
行程 Stroke:	42mm
剪切次数 Cutting times:	70times (饱和电压 Per saturation voltage)
剪切范围 Cutting range:	Φ70mm _{max} 铜/铝和铠装电缆 Armoured and Cu/Al cable
充电器电压 Charger voltage:	100-240VAC
电池电压/容量 Voltage/capacity:	18V/4.0Ah
净重 Net weight:	4.5kg
充电时间 Charging time:	2 hours
包装 Package:	塑料盒 Plastic box
配件 ACCESSORIES	
电池 Battery:	2pcs
充电器 Charger:	1pc



EA-105C 经济型液压剪切工具

技术参数 / TECHNICAL DATA

剪切力 Cutting force:	150KN
行程 Stroke:	62mm
剪切次数 Cutting times:	70times (饱和电压 Per saturation voltage)
剪切范围 Cutting range:	Φ85mm _{max} 铜/铝和铠装电缆 Armoured and Cu/Al cable
充电器电压 Charger voltage:	100-240VAC
电池电压/容量 Voltage/capacity:	18V/4.0Ah
净重 Net weight:	15kg/10-12kg
充电时间 Charging time:	2 hours
包装 Package:	塑料盒 Plastic box
配件 ACCESSORIES	
电池 Battery:	2pcs
充电器 Charger:	1pc



EA-120C 经济型液压剪切工具

技术参数 / TECHNICAL DATA

剪切力 Cutting force:	150KN
行程 Stroke:	62mm
剪切次数 Cutting times:	70times (饱和电压 Per saturation voltage)
剪切范围 Cutting range:	Φ100mm _{max} 铜/铝和铠装电缆 Armoured and Cu/Al cable
充电器电压 Charger voltage:	100-240VAC
电池电压/容量 Voltage/capacity:	18V/4.0Ah
净重 Net weight:	19kg/9kg
充电时间 Charging time:	2 hours
包装 Package:	塑料盒 Plastic box
配件 ACCESSORIES	
电池 Battery:	2pcs
充电器 Charger:	1pc



PLUG-IN TYPE HYDRAULIC TOOLS

EC-240H 插电式液压压接工具

技术参数 / TECHNICAL DATA	EC-240H
压接力 Crimping force:	80KN
行程 Stroke:	17mm
压接周期 Crimping cycle:	6-18s 取决于电缆的尺寸 Depend on the size of cable
电压 Voltage:	220V
净重 Net weight:	6kg
包装 Package:	塑料盒 Plastic box
配件 ACCESSORIES	
压接模具 Crimping dies:	16,25,35,50,70,95,120,150,185,240mm ²
碳刷 Carbon brush:	1pcs



EC-300 插电式液压压接工具

技术参数 / TECHNICAL DATA	EC-300
压接力 Crimping force:	60KN
行程 Stroke:	17mm
压接周期 Crimping cycle:	6-18s 取决于电缆的尺寸 Depend on the size of cable
电压 Voltage:	220V
净重 Net weight:	6.5kg
包装 Package:	塑料盒 Plastic box
配件 ACCESSORIES	
压接模具 Crimping dies:	16,25,35,50,70,95,120,150,185,240,300mm ²
碳刷 Carbon brush:	1pcs



EC-300B / EC-400B 插电式液压压接工具

技术参数 / TECHNICAL DATA	EC-300B	EC-400B
压接力 Crimping force:	60KN	120KN
行程 Stroke:	33mm	35mm
压接周期 Crimping cycle:	6-18s 取决于电缆的尺寸 Depend on the size of cable	6-18s 取决于电缆的尺寸 Depend on the size of cable
剪切功能 Cut function:		单芯铜铝电缆400mm ²
电压 Voltage:	220V	220V
净重 Net weight:	6.5kg	7kg
包装 Package:	塑料盒 Plastic box	塑料盒 Plastic box
配件 ACCESSORIES		
压接模具 Crimping dies:	EC-300B: 4,6,10,16,25,35,50,70,95,120,150,185,240,300mm ²	EC-400B: 4,6,10,16,25,35,50,70,95,120,150,185,240,300,400mm ²
碳刷 Carbon brush:	1pcs	1pcs



PLUG-IN TYPE HYDRAULIC TOOLS

EC-85C 插电式液压剪切工具

技术参数 / TECHNICAL DATA	EC-85C
剪切力 Cutting force:	120KN
行程 Stroke:	42mm
剪切范围 Cutting range:	Φ70mm _{max} 铜/铝和铠装电缆 Armoured and Cu/Al cable
电压 Voltage:	220V
净重 Net weight:	6.0kg
包装 Package:	塑料盒 Plastic box



插电式液压工具

EC-105C 插电式液压剪切工具

技术参数 / TECHNICAL DATA	EC-105C
剪切力 Cutting force:	150KN
行程 Stroke:	62mm
剪切范围 Cutting range:	Φ85mm _{max} 铜/铝和铠装电缆 Armoured and Cu/Al cable
电压 Voltage:	220V
毛重/净重 Gross weight/Net weight:	15g/10-12kg
包装 Package:	塑料盒 Plastic box



PLUG-IN TYPE HYDRAULIC TOOLS

EC-120C 插电式液压剪切工具

技术参数 / TECHNICAL DATA	EC-120C
剪切力 Cutting force:	150KN
行程 Stroke:	62mm
剪切范围 Cutting range:	Φ100mm _{max} 铜/铝和铠装电缆 Armoured and Cu/Al cable
电压 Voltage:	220V
毛重/净重 Gross weight/Net weight:	19kg/9kg
包装 Package:	塑料盒 Plastic box



EP-410 手动液压压接工具

技术参数 / TECHNICAL DATA	EP-410
压接力 Crimping force:	116KN
压接范围 Crimping range:	Cu50-400mm ²
行程 Stroke:	30mm
油量 Oil capacity:	145cc
重量 Weight:	6.4kg
包装 Package:	塑料盒 plastic box
箱子重量 Weight of box:	1.7kg
配件 ACCESSORIES:	
压接模具 Crimping dies: 50, 70, 95, 120, 150, 185, 240, 300,400mm ²	



内部有安全系统
With safety system inside

EP-430 手动液压压接工具

技术参数 / TECHNICAL DATA	EP-430
压接力 Crimping force:	116KN
压接范围 Crimping range:	Cu50-400mm ²
行程 Stroke:	30mm
油量 Oil capacity:	145cc
重量 Weight:	7.0kg
包装 Package:	塑料盒 plastic box
箱子重量 Weight of box:	1.7kg
配件 ACCESSORIES:	
压接模具 Crimping dies: 50, 70, 95, 120, 150, 185, 240, 300,400mm ²	



内部有安全系统
With safety system inside

EP-510 手动液压压接工具

技术参数 / TECHNICAL DATA	EP-510
压接力 Crimping force:	126KN
压接范围 Crimping range:	Cu50-400mm ²
行程 Stroke:	42mm
油量 Oil capacity:	145cc
重量 Weight:	7.4kg
包装 Package:	塑料盒 plastic box
重量 Weight of box:	1.7kg
配件 ACCESSORIES:	
压接模具 Crimping dies: 50, 70, 95, 120, 150, 185, 240, 300,400mm ²	



内部有安全系统
With safety system inside

产品特点:

- 设计可容纳六角形模具，用于将压缩凸耳应用于铜、铝导线。
- 两级泵送动作，以最小的泵送动作快速推进至接头保持位置。
- 当扭动手柄达到最大压力时，手动收回。
- 玻璃纤维操作绝缘棒，能承受200KV电压，保持分钟。
- 180°旋转头。
- 阀体外压力调节压阀，不需要整个结构躺下。

FEATURES:

- Design to accommodate hexagonal dies for applying compression lugs to copper, aluminum conductors.
- Two stage pumping action for rapid ram advance to the connector hold position with minimum pumping action.
- Manual retraction when the max pressure reached by twisting the handle.
- The glass fiber operation insulates the stick, can bear the electric voltage 200KV, keeping on the minute.
- 180° rotatable head.
- The pressure outside the body adjusts to press the valve, don't need the whole structure to lie down.

YQK-120 手动液压压接工具

技术参数/ TECHNICAL DATA	YQK-120
压接力 Crimping force:	60KN
压接范围 Crimping range:	Cu10-120mm ²
压接形式 Crimping type:	六角压接 hexagon crimping
行程 Stroke:	13mm
长度 Length:	415mm
重量 Weight:	2.8kg
包装 Package:	塑料盒 plastic box
箱子重量 Weight of box:	0.9kg
配件 ACCESSORIES:	
压接模具 Crimping dies: 10,16,25,35,50,70,95,120mm ²	



YQK-240 手动液压压接工具

技术参数/ TECHNICAL DATA	YQK-240
压接力 Crimping force:	70KN
压接范围 Crimping range:	Cu16-240mm ²
压接形式 Crimping type:	六角压接 hexagon crimping
行程 Stroke:	18mm
长度 Length:	475mm
重量 Weight:	3.6kg
包装 Package:	塑料盒 plastic box
箱子重量 Weight of box:	1.8kg
配件 ACCESSORIES:	
压接模具 Crimping dies: 16,25,35,50,70,95,120,150,185,240mm ²	



YQK-300 手动液压压接工具

技术参数/ TECHNICAL DATA	YQK-300
压接力 Crimping force:	70KN
压接范围 Crimping range:	Cu10-300mm ²
压接形式 Crimping type:	六角压接 hexagon crimping
行程 Stroke:	18mm
长度 Length:	475mm
重量 Weight:	3.6kg
包装 Package:	塑料盒 plastic box
箱子重量 Weight of box:	1.8kg
配件 ACCESSORIES:	
压接模具 Crimping dies: 10,16,25,35,50,70,95,120,150,185,240,300mm ²	



产品特点:

- 液压压接工具是用于压接不同型号铜、铝片的专业工具，压接模具范围从4mm²-1000mm²不等，可满足不同尺寸要求。主要卷曲形状为六角形，有特殊形状设计。

FEATURES:

- Hydraulic crimping tool is a professional tool for crimping copper and aluminum lugs with different types, a wide range of crimping dies from 4mm² to 1000mm² to suit for different size demand. The main crimping shape is hexagonal, special shape design is provided.

YQK-70 手动液压压接工具

技术参数/ TECHNICAL DATA	YQK-70
压接力 Crimping force:	45KN
压接范围 Crimping range:	Cu4-70mm ²
压接形式 Crimping type:	六角压接 hexagon crimping
行程 Stroke:	11mm
长度 Length:	310mm
重量 Weight:	1.8kg
包装 Package:	塑料盒 plastic box
箱子重量 Weight of box:	1.1kg
配件 ACCESSORIES:	
压接模具 Crimping dies:	4,6,8,10,16,25,35,50,70mm ²



YQK-120C 手动液压压接工具

技术参数/ TECHNICAL DATA	YQK-120C
压接力 Crimping force:	60KN
压接范围 Crimping range:	Cu10-120mm ²
压接形式 Crimping type:	六角压接 hexagon crimping
行程 Stroke:	13mm
长度 Length:	415mm
重量 Weight:	3.2kg
包装 Package:	塑料盒 plastic box
箱子重量 Weight of box:	0.9kg
配件 ACCESSORIES:	
压接模具 Crimping dies:	10,16,25,35,50,70,95,120mm ²



HK-300 手动液压压接工具

技术参数/ TECHNICAL DATA	HK-300
压接力 Crimping force:	100KN
压接范围 Crimping range:	Cu16-300mm ²
压接形式 Crimping type:	六角压接 hexagon crimping
行程 Stroke:	22mm
长度 Length:	490mm
重量 Weight:	4.6kg
包装 Package:	塑料盒 plastic box
箱子重量 Weight of box:	1.4kg
配件 ACCESSORIES:	
压接模具 Crimping dies:	16,25,35,50,70,95,120,150,185,240,300mm ²



产品特点:

- 液压压接工具是用于压接不同型号铜、铝片的专业工具，压接模具范围从4mm²-1000mm²不等，可满足不同尺寸要求。主要卷曲形状为六角形，有特殊形状设计。

FEATURES:

- Hydraulic crimping tool is a professional tool for crimping copper and aluminum lugs with different types, a wide range of crimping dies from 4mm² to 1000mm² to suit for different size demand. The main crimping shape is hexagonal, special shape design is provided.

KYQ-300B

技术参数/ TECHNICAL DATA	KYQ-300B
压接力 Crimping force:	100KN
压接范围 Crimping range:	Cu16-300mm ²
压接形式 Crimping type:	六角压接 hexagon crimping
行程 Stroke:	20mm
长度 Length:	500mm
重量 Weight:	4.4kg
包装 Package:	塑料盒 plastic box
箱子重量 Weight of box:	1.4kg
配件 ACCESSORIES:	
压接模具 Crimping dies: 16,25,35,50,70,95,120,150,185,240,300mm ²	



内部有安全系统
With safety system inside

KYQ-300C

技术参数/ TECHNICAL DATA	KYQ-300C
压接力 Crimping force:	100KN
压接范围 Crimping range:	Cu16-300mm ²
压接形式 Crimping type:	六角压接 hexagon crimping
行程 Stroke:	18mm
长度 Length:	500mm
重量 Weight:	4.5kg
包装 Package:	塑料盒 plastic box
箱子重量 Weight of box:	1.4kg
配件 ACCESSORIES:	
压接模具 Crimping dies: 16,25,35,50,70,95,120,150,185,240,300mm ²	



内部有安全系统
With safety system inside

KYQ-400

技术参数/ TECHNICAL DATA	KYQ-400
压接力 Crimping force:	105KN
压接范围 Crimping range:	Cu50-400mm ²
压接形式 Crimping type:	六角压接 hexagon crimping
行程 Stroke:	32mm
长度 Length:	530mm
重量 Weight:	6.2kg
包装 Package:	塑料盒 plastic box
箱子重量 Weight of box:	1.4kg
配件 ACCESSORIES:	
压接模具 Crimping dies: 50,70,95,120,150,185,240,300,400mm ²	



产品特点:

- 液压压接工具是用于压接不同型号铜、铝片的专业工具，压接模具范围从4mm²-1000mm²不等，可满足不同尺寸要求。主要卷曲形状为六角形，有特殊形状设计。

FEATURES:

- Hydraulic crimping tool is a professional tool for crimping copper and aluminum lugs with different types, a wide range of crimping dies from 4mm² to 1000mm² to suit for different size demand. The main crimping shape is hexagonal, special shape design is provided.

HT-300



内部有安全系统
With safety system inside

产品特点:

- 该工具具有双重速度作用：快进的速度可快速将刀片推入连接器，而慢速的功率则更大，可进行压接。
- 为了操作简便和舒适，操作员可以将工具头完全旋转350°。
- 当达到最大压力时，内置的安全阀将旁路供油，并且压力释放系统可在压缩的任何阶段轻松操作。
- 具有可互换的模具。

技术参数/ TECHNICAL DATA

HT-300

压接力 Crimping force:	60KN
压接范围 Crimping range:	Cu16-300mm ²
压接形式 Crimping type:	六角压接 hexagon crimping
行程 Stroke:	17mm
长度 Length:	465mm
重量 Weight:	3.3kg
包装 Package:	钢制外壳 steel case

配件 ACCESSORIES:

压接模具 Crimping dies: 16,25,35,50,70,95,120,150,185,240,300mm²

FEATURES:

- The tool features a double speed action: a fast advancing speed for rapid approach of the blades to the connector and a slower more powerful speed for crimping.
- For ease of operation and comfort the operator the tool head can be fully rotated through 350° degrees.
- The built-in safety valve will by-pass the oil supply when the maximum pressure is reached, and the pressure release system can easily be operated at any stage of compression.
- With interchangeable dies.

HT-400



内部有安全系统
With safety system inside

产品特点:

- 刀具具有C型刀头。 • 可更换模具。
- 为了便于操作和舒适，操作员可以使刀头完全旋转刀具350°。
- 双速动作，反映为快速接近压接模连接器的快速前进速度和更慢更强大的压接速度。
- 当达到最大压力时，内置安全阀将旁通供油，自动泄压。
- 压接后手动收回。

技术参数/ TECHNICAL DATA

HT-400

压接力 Crimping force:	120KN
压接范围 Crimping range:	Cu16-400mm ²
压接形式 Crimping type:	六角压接 hexagon crimping
行程 Stroke:	42mm
长度 Length:	540mm
重量 Weight:	6.3kg
包装 Package:	钢制外壳 steel case

配件 ACCESSORIES:

压接模具 Crimping dies: 16,25,35,50,70,95,120,150,185,240,300,400mm²

FEATURES:

- The tool features with C type head. • Inter change able dies.
- For ease of operation and comfort the operator can make the tool head fully rotated tool 350°.
- A double speed action reflected by a fast advancing speed for rapid approach of the crimping die the connector and a slower more powerful speed for crimping.
- The built-in safety valve will by-pass the oil supply when the maximum pressure is reached, automatically pressure release.
- Manual retract after crimping.

HT-400U



内部有安全系统
With safety system inside

产品特点:

- 工具具有H型刀头。
- 可更换模具。
- 为了便于操作和舒适，操作员可以使刀头完全旋转刀具350°。
- 双速动作，反映为快速接近压接模连接器的快速前进速度和更慢更强大的压接速度。
- 当达到最大压力时，内置安全阀将旁通供油，自动泄压。
- 压接后手动收回。

技术参数/ TECHNICAL DATA

HT-400U

压接力 Crimping force:	120KN
压接范围 Crimping range:	Cu16-400mm ²
压接形式 Crimping type:	六角压接 hexagon crimping
行程 Stroke:	20mm
长度 Length:	520mm
重量 Weight:	5.3kg
包装 Package:	钢制外壳 steel case

配件 ACCESSORIES:

压接模具 Crimping dies: 16,25,35,50,70,95,120,150,185,240,300,400mm²

FEATURES:

- The tool features with H type head.
- Inter change able dies.
- For ease of operation and comfort the operator can make the tool head fully rotated tool 350°.
- A double speed action reflected by a fast advancing speed for rapid approach of the crimping die the connector and a slower more powerful speed for crimping.
- The built-in safety valve will by-pass the oil supply when the maximum pressure is reached, automatically pressure release.
- Manual retract after crimping.

THS-150

内部有安全系统
With safety system inside



技术参数 / TECHNICAL DATA

型号 Model No:	THS-150
压接力 Crimping force:	60KN
压接范围 Crimping range:	Cu10-150mm ²
压接形式 Crimping type:	六角压接 hexagon crimping
行程 Stroke:	15mm
长度 Length:	380mm
重量 Weight:	2.2kg
油量 Oil capacity:	60cc
包装 Package:	塑料盒 plastic box
配件 ACCESSORIES:	
压接模具 Crimping dies: 10,16,25,35,50,70,95,120,150mm ²	

产品特点:

- THS-150设计用于接受欧洲国家广泛使用的BEKU型机械工具模具。
- 重量轻、纤细的设计是近距离应用的理想选择，例如开关箱中的连接。
- 易插销式闭合头，便于插拔连接器。弹簧加载泵单手泵送手柄，直到下模固定住模具之间的接头。
- 当达到最大压力和压力时，内置安全阀将旁通供油释放系统可以在任何压缩阶段轻松操作。



FEATURES:

- The THS-150 is designed to accept dies for BEKU type mechanical tool widely used in European countries.
- The light weight and slim design is ideal for close quarter application such as connection in the switch box.
- Easy latch type closed head provides easy insertion and removal of connectors. The spring loaded pump handle allows one hand pumping until lower die holds connector between dies.
- The built-in safety valve will by-pass the oil supply when the maximum pressure is reached and the pressure release system can easily be operated at any stage of compression.

CO-25

产品特点 FEATURES:

- 该工具具有H型头
- 可更换模具
- 为了便于操作和舒适, 操作员可以使工具头完全旋转工具350°
- 一种双速动作, 反映了快速前进的速度以快速压连接器, 而降低的速度则更慢
- 当达到最大压力时, 内置的安全阀将旁路供油, 自动释放压力
- 压接后手动缩回
- The tool features with H type head.
- Inter change able dies.
- For ease of operation and comfort the operator can make the tool head fully rotated tool 350°.
- A double speed action reflected by a fast advancing speed for rapid approach of the crimping die the connector and a slower more powerful speed for crimping.
- The built-in safety valve will by-pass the oil supply when the maximum pressure is reached, automatically pressure release.
- Manual retract after crimping.

技术参数 / TECHNICAL DATA

型号 Model No:	CO-25
输出量 Output:	230KN
压接范围 Crimping range:	16-630mm ²
额定压力 Rated pressure:	70Mpa (700bar)
尺寸 Size:	320X95X120mm
重量 Weight:	5.3kg (没有模具 without die set)
包装 Package:	精钢表壳 Steel case
配件 ACCESSORIES:	
压接模具 Crimping dies:	150, 185, 240, 300, 400, 500, 630mm ²
注意 Note:	它可以匹配手动泵 in can match hand pump CP-700



CO-45

技术参数 / TECHNICAL DATA

型号 Model No:	CO-45
输出量 Output:	450KN
压接范围 Crimping range:	120-1000mm ²
额定压力 Rated pressure:	70Mpa (700bar)
尺寸 Size:	265X230X115
重量 Weight:	11kg (没有模具 without die set)
包装 Package:	精钢表壳 Steel case
配件 ACCESSORIES:	
压接模具 Crimping dies:	400, 500, 630, 800, 1000mm ²
注意 Note:	它可以匹配手动泵 in can match hand pump CP-700



CO-60

产品特点 FEATURES:

- 高强度优质合金钢材料, 经过高科技加热处理, 确保使用寿命和模具强度
- 旋转并取出模具支架以改变压接尺寸, 便于携带导体
- 高强度弹簧可快速缩回
- High-strength superior alloy steel material, after high technology heating process to ensure the life span and tooling strength.
- Rotate and take out the die holder to change the crimping size, easy to bring the conductor.
- High-strength spring make the retraction fast

技术参数 / TECHNICAL DATA

型号 Model No:	CO-60
额定输出 Rated output:	605KN(61.8T)
额定压力 Rated pressure:	70Mpa(700bar)
活塞行程 Piston stroke:	35mm
机油容量 Oil capacity:	316ml
净重 Net weight:	20kg
缩回模式 Retract mode:	弹簧缩回(单动) Spring retraction(Single action)
铜套管 Cooper sleeve pipe:	Φ60mm
铝套管 Aluminum sleeve pipe:	Φ60mm
钢套管 Steel sleeve pipe:	Φ26mm

注意: 为了满足需求, 请在订货时提供合适的尺寸和标准的管子
NOTE: In order to meet the demand please provide appropriate size and a standard of tube when place order.



分体式压接头部 SPILT-TYPE CRIMPING HEAD

EP-300H

型号 Model No:	EP-300H
压接范围 Crimping range:	16-300mm ² 铜导体 Cu-conductors 10-240mm ² 铝导体 Al-conductors
压接力 Crimping force:	60KN
压接类型 Crimping type:	六角压接 hexagon crimping
行程 Stroke:	17mm
重量 Weight:	approx.2.5kg
包装 Package:	塑料盒 plastic box
包装箱重量 Weight of box:	approx.2.5kg
配件 ACCESSORIES:	
压接模具 Crimping dies:	16,25,35,50,70,95,120,150,185,240,300mm ²
注意 Note:	可以匹配手动泵 In can match hand pump



- 分体式液压力压接头可与液压泵配合使用
- 适用于配电室内外工程，是各种连接和架空电缆的专用工具

- Split hydraulic crimping head can work with hydraulic pump.
- It is suitable for outside and inside project of the distributo house, it is thespecial tools for all kinds of connecting and building over head cable.

EP-430H

型号 Model No:	EP-430H
压接范围 Crimping range:	Cu 50-400mm ²
压接力 Crimping force:	116KN
压接类型 Crimping type:	六角压接 hexagon crimping
行程 Stroke:	30mm
长度 Length:	approx.330mm
重量 Weight:	approx.4.7kg
包装 Package:	塑料盒 plastic box
包装箱重量 Weight of box:	approx.3.5kg
配件 ACCESSORIES:	
压接模具 Crimping dies:	50,70,95,120,150,185,240,300,400mm ²
注意 Note:	可以匹配CP-700手动泵 In can match hand pump CP-700



- 分体式液压力压接头可与液压泵配合使用，适合压接大尺寸的凸耳
- 适用于配电房的内外工程，是各种连接和架空电缆的专用工具

- Split hydraulic crimping head can work with hydraulic pump.it is suit for crimping big size of lugs.
- It is suitable for outside and inside project of the distributo house, it is thespecial tools for all kinds of connecting and building over head cable.

EP-510H

型号 Model No:	EP-510H
压接范围 Crimping range:	Cu 50-400mm ²
压接力 Crimping force:	126KN
压接类型 Crimping type:	六角压接 hexagon crimping
行程 Stroke:	38mm
长度 Length:	approx.370mm
重量 Weight:	approx.4.9kg
包装 Package:	塑料盒 plastic box
包装箱重量 Weight of box:	approx.3.5kg
配件 ACCESSORIES:	
压接模具 Crimping dies:	50,70,95,120,150,185,240,300,400mm ²
注意 Note:	可以匹配CP-700手动泵 In can match hand pump CP-700



- 分体式液压力压接头可与液压泵配合使用，适合压接大尺寸的凸耳
- 适用于配电房的内外工程，是各种连接和架空电缆的专用工具

- Split hydraulic crimping head can work with hydraulic pump.it is suit for crimping big size of lugs.
- It is suitable for outside and inside project of the distributo house, it is thespecial tools for all kinds of connecting and building over head cable.

FYQ-400 / 500

型号 Model No	FYQ-400/500	出力 Output	20T
行程 Stroke	20mm	包装 Package	硬纸箱 Cardboard box
压接形式 Crimping form	六角围压 Hexagon	净重/毛重 Net weight / gross weight	5.6kg/11kg (含包装+模具)
压接范围 Crimping range	(FYQ-400型) 铜: 16-400mm ² (FYQ-500型) 铜: 16-500mm ²	铝16-300mm ² 铝16-400mm ²	
模具配置 Mold configuration	(FYQ-400型) 16, 25, 35, 50, 70, 95, 120, 150, 185, 240, 300, 400mm ² (FYQ-500型) 16, 25, 35, 50, 70, 95, 120, 150, 185, 240, 300, 400, 500mm ²		

- 可以与手动液压泵 (CP-180, CP-700) 一起使用, 以在不通电的情况下压接铜鼻子和铝鼻子
- 还可以配备电动液压泵 (DYB-63A, QQ-700), 大大提高工作效率
- 适用于输配电层的室内外工程, 各种连接配件, 架空地线的专业使用
- 10KV-500KV高压电缆套管, 线夹, 裸端子, 六角形压接, 紧固且不脱落
- It can be used with manual hydraulic pumps (CP-180, CP-700) to crimp copper and aluminum noses without power.
- It can also be equipped with electric hydraulic pumps (DYB-63A, QQ-700) to greatly improve work efficiency.
- It is suitable for the indoor and outdoor projects of the transmission and distribution layer, various connecting fittings, and professional use of overhead ground cables.
- 10KV-500KV high-voltage cable bushings, clamps, bare terminals, hexagonal crimping, tightly and not falling off.



FYQ-630

型号 Model No	FYQ-630	出力 Output	35T
行程 Stroke	25mm	压接范围 Crimping range	150-630mm ²
压接形式 Crimping form	六角围压 Hexagon	重量 Weight	17.5kg
模具配置 Mold configuration	150, 185, 240, 300, 400, 500, 630mm ²		

- 适用于输配电层的室内外工程, 各种连接配件, 架空地线的专业使用
- 10KV-500KV高压电缆套管, 线夹, 裸端子, 六角形压接, 紧密且不脱落
- 需要与泵一起使用 (例如CP-700, DYB-63A电动泵, QQ-700电动泵等)
- It is suitable for the indoor and outdoor projects of the transmission and distribution layer, various connecting fittings, and professional use of overhead ground cables.
- 10KV-500KV high-voltage cable bushings, clamps, bare terminals, hexagonal crimping, tightly and not falling off.
- Need to be used with pumps (such as CP-700, DYB-63A electric pump, QQ-700 electric pump, etc.)



CO-100S-1

型号 Model No	CO-100S-1	出力 Output	100T
行程 Stroke	24mm	净重 Net weight	33kg
压接形式 Crimping form	六角围压 Hexagon	包装 Package	木箱 Wooden box
压接范围 Crimping range	钢铝端子套管Φ65, 铜套管800mm ² Cu/Al terminal sleeve Φ65, copper sleeve 800mm ²		

- 适用于110KV以上架空耐张套管压接, 以及地下电缆之连续作业
- 最大套管尺寸Φ65mm, 压接面宽, 压接次数少, 可降低压接变形以及控制伸长率
- 复动式液压油缸可免除弹簧弹性疲乏复位慢的问题, 同时可缩短活塞复位时间
- 可移动式模具盖可以协助操作人员压接之后容易取出模具
- 旋转式模具盖可快速开启以及闭合, 使操作定位更容易;
- 简单设计维修容易
- 必须搭配双油路液压电动泵或汽油机泵, 出厂不含泵, 客户可自由选配
- 出厂不含模具, 具体模具规格型号需根据客户需求另配
- Suitable for crimping of overhead tensile casing above 110KV and continuous operation of underground cables.
- Maximum casing size Φ65mm, wide crimping surface, less crimping times, reducing crimping deformation and controlling elongation.
- Double-acting hydraulic cylinder can avoid the problem of slow reset of spring elastic fatigue, and shorten the reset time of piston at the same time.
- The movable mold cover can assist the operator to easily take out the mold after crimping.
- The rotary mold cover can be opened and closed quickly, making the operation and positioning easier.
- Simple design and easy maintenance.
- Must be equipped with dual oil circuit hydraulic electric pump or gasoline engine pump, the factory does not contain a pump, customers can freely choose.
- The factory does not contain molds, the specific mold specifications and models need to be equipped according to customer needs.



CUTTER SERIES

剪刀系列

EMEADS[®]
ZHEJIANG EMEADS TOOLS CO., LTD



**进口电机
强劲动力**

**POWERFUL POWER
AND EFFICIENT OPERATION**

135C CHARGING TYPE HYDRAULIC CABLE CUTTER

25吨EBS-135C



25吨EB-135C



25吨DES-135C (无刷驱动)



25吨DE-135C (无刷驱动)



技术参数 / TECHNICAL DATA

剪切力 Cutting force:	200KN
行程 Stroke:	62mm
剪切次数 Cutting times:	40times (饱和电压 Per saturation voltage) (4.0标配)
剪切范围 Cutting range:	Φ130mm _{max} 铜/铝和铠装电缆 Armoured and Cu/Al cable
电池电压/容量 Voltage/capacity:	18V/4.0Ah/9.0Ah
毛重/净重 Gross weight/Net weight:	24kg/11kg
充电时间 Charging time:	2 hours
包装 Package:	塑料盒 Plastic box
配件 ACCESSORIES	
电池 Battery:	2pcs
充电器 Charger:	1pc



120C CHARGING TYPE HYDRAULIC CABLE CUTTER

25吨EBS-120C



连续剪切功能型
With continuous function

25吨EB-120C



常规功能型
Regular function

25吨DES-120C (无刷驱动)



连续剪切功能型
With continuous function

25吨DE-120C (无刷驱动)



常规功能型
Regular function

技术参数 / TECHNICAL DATA

剪切力 Cutting force:	200KN
行程 Stroke:	62mm
剪切次数 Cutting times:	50times (饱和电压 Per saturation voltage)
剪切范围 Cutting range:	Φ110mm _{max} 铜/铝和铠装电缆 Armoured and Cu/Al cable
电池电压/容量 Voltage/capacity:	18V/4.0Ah/9.0Ah
毛重/净重 Gross weight/Net weight:	23kg/11kg
充电时间 Charging time:	2 hours
包装 Package:	塑料盒 Plastic box
配件 ACCESSORIES	
电池 Battery:	2pcs
充电器 Charger:	1pc



120C CHARGING TYPE HYDRAULIC CABLE CUTTER

15吨EBS-120C



15吨EB-120C



15吨DES-120C (无刷驱动)



15吨DE-120C (无刷驱动)



技术参数 / TECHNICAL DATA

剪切力 Cutting force:	150KN
行程 Stroke:	62mm
剪切次数 Cutting times:	50times (饱和电压 Per saturation voltage)
剪切范围 Cutting range:	Φ100mm _{max} 铜/铝和铠装电缆 Armoured and Cu/Al cable
电池电压/容量 Voltage/capacity:	18V/4.0Ah/9.0Ah
毛重/净重 Gross weight/Net weight:	19kg/9kg
充电时间 Charging time:	2 hours
包装 Package:	塑料盒 Plastic box
配件 ACCESSORIES	
电池 Battery:	2pcs
充电器 Charger:	1pc



105C CHARGING TYPE HYDRAULIC CABLE CUTTER

25吨EBS-105C



25吨EB-105C



25吨DES-105C (无刷驱动)



25吨DE-105C (无刷驱动)



技术参数 / TECHNICAL DATA

剪切力 Cutting force:	200KN
行程 Stroke:	62mm
剪切次数 Cutting times:	70times (饱和电压 Per saturation voltage)
剪切范围 Cutting range:	Φ100mm _{max} 铜/铝和铠装电缆 Armoured and Cu/Al cable
电池电压/容量 Voltage/capacity:	18V/4.0Ah/9.0Ah
毛重/净重 Gross weight/Net weight:	23kg/10-12kg
充电时间 Charging time:	2 hours
包装 Package:	塑料盒 Plastic box
配件 ACCESSORIES	
电池 Battery:	2pcs
充电器 Charger:	1pc



105C CHARGING TYPE HYDRAULIC CABLE CUTTER

15吨EBS-105C



连续压接功能型
With continuous function

15吨EB-105C



常规功能型
Regular function

15吨DES-105C (无刷驱动)



连续压接功能型
With continuous function

15吨DE-105C (无刷驱动)



常规功能型
Regular function

技术参数 / TECHNICAL DATA

剪切力 Cutting force:	150KN
行程 Stroke:	62mm
剪切次数 Cutting times:	70times (饱和电压 Per saturation voltage)
剪切范围 Cutting range:	Φ85mm _{max} 铜/铝和铠装电缆 Armoured and Cu/Al cable
电池电压/容量 Voltage/capacity:	18V/4.0Ah/9.0Ah
毛重/净重 Gross weight/Net weight:	15g/10-12kg
充电时间 Charging time:	2 hours
包装 Package:	塑料盒 Plastic box
配件 ACCESSORIES	
电池 Battery:	2pcs
充电器 Charger:	1pc



105 CHARGING TYPE HYDRAULIC CABLE CUTTER

EBS-105



连续剪切功能型
With continuous function

EB-105



常规功能型
Regular function

DES-105 (无刷驱动)



连续剪切功能型
With continuous function

DE-105 (无刷驱动)



常规功能型
Regular function

技术参数 / TECHNICAL DATA

剪切力 Cutting force:	120KN
行程 Stroke:	105mm
剪切次数 Cutting times:	130times (饱和电压 Per saturation voltage)
剪切范围 Cutting range:	Φ95mm _{max} 铜/铝和铠装电缆 Armoured and Cu/Al cable
电池电压/容量 Voltage/capacity:	18V/4.0Ah/9.0Ah
净重 Net weight:	6.5kg
充电时间 Charging time:	2 hours
包装 Package:	塑料盒 Plastic box
配件 ACCESSORIES	
电池 Battery:	2pcs
充电器 Charger:	1pc



85C CHARGING TYPE HYDRAULIC CABLE CUTTER

EBS-85C



连续压接功能型
With continuous function

EB-85C



常规功能型
Regular function

DES-85C (无刷驱动)



连续压接功能型
With continuous function

DE-85C (无刷驱动)



常规功能型
Regular function

技术参数 / TECHNICAL DATA

剪切力 Cutting force:	120KN
行程 Stroke:	42mm
剪切次数 Cutting times:	70times (饱和电压 Per saturation voltage)
剪切范围 Cutting range:	Φ70mm _{max} 铜/铝和铠装电缆 Armoured and Cu/Al cable
电池电压/容量 Voltage/capacity:	18V/4.0Ah/9.0Ah
净重 Net weight:	6.0kg
充电时间 Charging time:	2 hours
包装 Package:	塑料盒 Plastic box
配件 ACCESSORIES	
电池 Battery:	2pcs
充电器 Charger:	1pc



85 CHARGING TYPE HYDRAULIC CABLE CUTTER

EBS-85



连续剪切功能型
With continuous function

EB-85



常规功能型
Regular function

DES-85 (无刷驱动)



连续剪切功能型
With continuous function

DE-85 (无刷驱动)



常规功能型
Regular function

技术参数 / TECHNICAL DATA

剪切力 Cutting force:	60KN
行程 Stroke:	85mm
剪切次数 Cutting times:	130times (饱和电压 Per saturation voltage)
剪切范围 Cutting range:	Φ70mm _{max} 铜/铝和铠装电缆 Armoured and Cu/Al cable
电池电压/容量 Voltage/capacity:	18V/4.0Ah
净重 Net weight:	6.0kg
充电时间 Charging time:	2 hours
包装 Package:	塑料盒 Plastic box
配件 ACCESSORIES	
电池 Battery:	2pcs
充电器 Charger:	1pc



55 CHARGING TYPE HYDRAULIC CABLE CUTTER

EBS-55



连续压接功能型
With continuous function

DES-55 (无刷驱动)



连续压接功能型
With continuous function

EB-55



常规功能型
Regular function

DE-55 (无刷驱动)



常规功能型
Regular function

技术参数 / TECHNICAL DATA

剪切力 Cutting force:	120KN
行程 Stroke:	50mm
剪切次数 Cutting times:	70times (饱和电压 Per saturation voltage)
剪切范围 Cutting range:	Φ50mm _{max} 铜/铝/铠装电缆/钢芯铝绞线 Armoured and Cu/Al cable/ACSR stranded wire
电池电压/容量 Voltage/capacity:	18V/4.0Ah
净重 Net weight:	6.0kg
充电时间 Charging time:	2 hours
包装 Package:	塑料盒 Plastic box
配件 ACCESSORIES	
电池 Battery:	2pcs
充电器 Charger:	1pc



40 CHARGING TYPE HYDRAULIC CABLE CUTTER

EBS-40



连续剪切功能型
With continuous function

EB-40



常规功能型
Regular function

DES-40 (无刷驱动)



连续剪切功能型
With continuous function

DE-40 (无刷驱动)



常规功能型
Regular function

技术参数 / TECHNICAL DATA

剪切力 Cutting force:	60KN/120KN (120KN可选配钳头)
行程 Stroke:	40mm
剪切次数 Cutting times:	130times (饱和电压 Per saturation voltage)
剪切范围 Cutting range:	Φ35mm _{max} 钢芯铝绞线 ACSR stranded wire
电池电压/容量 Voltage/capacity:	18V/4.0Ah
净重 Net weight:	6.0kg
充电时间 Charging time:	2 hours
包装 Package:	塑料盒 Plastic box
配件 ACCESSORIES	
电池 Battery:	2pcs
充电器 Charger:	1pc



MINI CHARGING TYPE HYDRAULIC CABLE CUTTER

GE-85C

技术参数 / TECHNICAL DATA	GE-85C
剪切力 Cutting force:	120KN
行程 Stroke:	35mm
剪切次数 Cutting times:	130times (饱和电压 Per saturation voltage)
剪切范围 Cutting range:	Φ70mm _{max} 铜/铝和铠装电缆 Armoured and Cu/Al cable
电池电压/容量 Voltage/capacity:	18V/4.0Ah
净重 Net weight:	4.0kg
充电时间 Charging time:	2 hours
包装 Package:	塑料盒 Plastic box
配件 ACCESSORIES	
电池 Battery:	2pcs
充电器 Charger:	1pc



GE-65C (钢芯铝绞线专用)

技术参数 / TECHNICAL DATA	GE-65C
剪切力 Cutting force:	120KN
行程 Stroke:	35mm
剪切次数 Cutting times:	130times (饱和电压 Per saturation voltage)
剪切范围 Cutting range:	Φ55mm _{max} 钢芯铝绞线 ACSR stranded wire
电池电压/容量 Voltage/capacity:	18V/4.0Ah
净重 Net weight:	4.0kg
充电时间 Charging time:	2 hours
包装 Package:	塑料盒 Plastic box
配件 ACCESSORIES	
电池 Battery:	2pcs
充电器 Charger:	1pc



GES-32C / GES-50C

技术参数 / TECHNICAL DATA	GES-32C	GES-50C
剪切力 Cutting force:	60KN	60KN
行程 Stroke:	30mm	35mm
剪切次数 Cutting times:	130times (饱和电压 Per saturation voltage)	130times (饱和电压 Per saturation voltage)
剪切范围 Cutting range:	Φ30mm _{max} 铜/铝/铠装电缆/钢芯铝绞线 Armoured and Cu/Al cable/ACSR stranded wire	Φ50mm _{max} 铜/铝/铠装电缆/钢芯铝绞线 Armoured and Cu/Al cable/ACSR stranded wire
电池电压/容量 Voltage/capacity:	18V/4.0Ah	18V/4.0Ah
净重 Net weight:	4.5kg	5.0kg
充电时间 Charging time:	2 hours	2 hours
包装 Package:	塑料盒 Plastic box	塑料盒 Plastic box
配件 ACCESSORIES		
电池 Battery:	2pcs	2pcs
充电器 Charger:	1pc	1pc

