

EB-15100

EMEADS[®]
ZHEJIANG EMEADS TOOLS CO., LTD

充电式液压卡压工具

CHARGING TYPE HYDRAULIC CLAMPING TOOL

另有型号可选：DE、DES无刷驱动
Other models: DE, DES brushless drive

适用卡压不锈钢水管，
消防碳钢管道、
燃气碳钢管道、
多层复合管

The tool is applicable to stainless steel pipe, fire carbon steel pipe, gas carbon steel pipe and multi-layer composite pipe



铜管
Copper tube



多层复合管
Multilayer composite tube



PEX管
PEX pipe



不锈钢管
Stainless steel pipe



碳钢管
Carbon steel pipe



电池 Battery



充电器 Charger

不锈钢管道压接套装

STAINLESS STEEL PIPE CRIMPING KIT



燃气/消防环压型套装

GAS/FIRE RING COMPRESSION TYPE SUIT



注：15-100(可选配压模)

Note: 15-100 (optional pressure die)

技术参数 / TECHNICAL DATA:

卡压范围 Compression range:	12-54mm(1/2"-2") 12-108mm(1/2"-4")	{ 薄壁不锈钢管、消防/燃气碳钢管 } { 塑料管、铝塑复合管、铜管 }	标配电池 Standard battery:	18V / 4.0Ah 锂电池 18V / 4.0Ah lithium battery
注意：不同管件类型及材质，卡压范围会有所变化，具体应根据配套管件而定 Note: different pipe type and material, compression range will change, should be based on the specific supporting pipe	12-54mm (1/2"-2") 12-108mm (1/2"-4")	{ Thin-wall stainless steel pipe, fire/gas carbon steel pipe } { Plastic pipe, aluminum plastic composite pipe, copper pipe }	标配充电器 Standard charger:	AC 100V~240V 50~60Hz
额定出力 Rated output:	40KN (活塞出力 Piston output)		电池充电时间 Battery charging time:	约2小时 (About 2 hours)
行程 Trip:	95mm		保养周期 Maintenance cycle:	30000次(times)
储油量 Oil storage:	250ml		每饱和电池卡压次数 Number of stuck voltage per saturated battery:	约360次 (DN20不锈钢管接头) About 360 times(DN20Stainless steel pipe joint)
单次卡压耗时 Time consumption of single clamping:	3-8s (根据管件的直径) 3-8s (According to the diameter of the pipe fitting)		毛重 Gross weight:	6.5kg
			工具尺寸 Tool dimensions:	525x318x86mm

配件 / ACCESSORIES:

电池 Battery:	2 pieces	充电器 Charger:	1 piece	模具配置 Mold configuration:	15, 20, 25, 32, 40, 50, 65, 80, 100mm 不锈钢水管(默认)、燃气管选配、消防管选配
-------------	----------	--------------	---------	--------------------------	--

便携轻巧 高效作业

LIGHT & EFFICIENT

将碳钢管表面涂层损伤降到最低!

Minimize coating damage on carbon steel pipes!



镀镍防锈压模
Nickel plated anti rust die



GE-260电动泵
Electric pump



应用广泛
Widely used



提高效率
High efficiency

技术参数 / TECHNICAL DATA:

卡压范围 Compression range:	12-54mm(1/2"-2") 12-108mm(1/2"-4")	{ 薄壁不锈钢管、消防/燃气碳钢管 } { 塑料管、铝塑复合管、铜管 }
	12-54mm (1/2"-2") 12-108mm (1/2"-4")	{ Thin-wall stainless steel pipe, fire/gas carbon steel pipe } { Plastic pipe, aluminum plastic composite pipe, copper pipe }

注意: 不同管件类型及材质, 卡压范围会有所变化, 具体应根据配套管件而定
Note: different pipe type and material, compression range will change, should be based on the specific supporting pipe

额定出力 Rated output: 40KN (活塞出力 Piston output)

行程 Trip: 95mm

储油量 Oil storage: 250ml

单次卡压耗时
Time consumption of single clamping: 3-8s (根据管件的直径)
3-8s (According to the diameter of the pipe fitting)

工具尺寸 Tool dimensions: 525x318x86mm

重量 Weight: 1.5kg

配件 / ACCESSORIES:

模具配置 Mold configuration: 15, 20, 25, 32, 40, 50, 65, 80, 100mm
不锈钢水管(默认)、燃气管选配、消防管选配



铜管
Copper tube



多层复合管
Multilayer composite tube



PEX管
PEX pipe



不锈钢管
Stainless steel pipe



碳钢管
Carbon steel pipe

SC-15100

分体式液压卡压工具

SPLIT HYDRAULIC PIPE CLAMPING TOOL

EMEADS[®]
ZHEJIANG EMEADS TOOLS CO.,LTD

实用新型专利产品

Utility model patented product

不锈钢管道压接套装

STAINLESS STEEL PIPE CRIMPING KIT



燃气/消防环压型套装

GAS/FIRE RING COMPRESSION TYPE SUIT



注:

- SC-15100不含电动泵
- SC-15100可搭配GE-260电动泵使用

Note:

- SC-15100 without electric pump
- SC-15100 can be used with GE-260 electric pump

注: 15-100(可选配压模)

Note: 15-100 (optional pressure die)

便携轻巧 高效作业

LIGHT & EFFICIENT



镀镍防锈压模
Nickel plated anti rust die



GE-260电动泵
Electric pump



应用广泛
Widely used



提高效率
High efficiency

SC-1550

EMEADS[®]
ZHEJIANG EMEADS TOOLS CO., LTD

分体式液压卡压工具

SPLIT HYDRAULIC PIPE CLAMPING TOOL

轻松操作 稳定可靠

EASY OPERATION, STABLE AND RELIABLE

适用于卡压不锈钢水管、铜管、 多层复合管

The tool is applicable to clamping stainless steel water pipe, copper pipe and multi-layer composite pipe



铜管
Copper tube



多层复合管
Multilayer
composite tube



不锈钢管
Stainless steel pipe



PEX管
PEX pipe



- 注：
 • SC-1550不含电动泵
 • SC-1550可搭配GE-260电动泵使用
- Note:**
 • SC-1550 without electric pump
 • SC-1550 can be used with GE-260 electric pump

技术参数 / TECHNICAL DATA:

卡压范围 Compression range:	12-54mm(1/2"-2") 薄壁不锈钢管、塑料管、铝塑复合管、铜管 12-54mm (1/2"-2") Thin-wall stainless steel pipe, Plastic pipe, aluminum plastic composite pipe, copper pipe
----------------------------	--

注意：不同管件类型及材质，卡压范围会有所变化，具体应根据配套管件而定
 Note: different pipe type and material, compression range will change, should be based on the specific supporting pipe

额定出力 Rated output:	32KN (活塞出力 Piston output)
行程 Trip:	40mm
单次卡压耗时 Time consumption of single clamping:	3-4.5s (根据管件的直径) 3-4.5s (According to the diameter of the pipe fitting)
工具尺寸 Tool dimensions:	450x81x128mm
重量 Weight:	2.5kg

配件 / ACCESSORIES:

模具配置 Mold configuration:	15, 20, 25, 32, 40, 50mm
--------------------------	--------------------------





4G

远程控制

4G remote control

性能稳定可靠 性价比高

Stable performance, high cost performance



一键启动
One touch start



蓝牙功能
Bluetooth function



安全保障
Security

GE-260

(可调压力功能)
(Adjustable pressure function)

充电式电动液压泵 CHARGING TYPE ELECTRIC HYDRAULIC PUMP

小身体 大能量

SMALL BODY, BIG ENERGY

功能可选:

Optional functions:

蓝牙APP远程控制
Bluetooth remote control

遥控器控制
Remote control



技术参数 / TECHNICAL DATA:

压接力 Crimping force:	70Mpa/40Mpa
储油量 Oil Reserve:	260ml
功率 Power:	279w
标配电池 Standard battery:	18V / 4.0Ah 锂电池 18V / 4.0Ah lithium battery
标配充电器 Standard charger:	AC 100V~240V 50~60Hz
电池充电时间 Battery charging time:	约2小时 (About 2 hours)
启动工作方式 Start working mode:	手动开关+蓝牙APP远程控制+遥控器20米 Manual switch+Bluetooth APP remote control+remote control 20m
适用范围 Scope of application:	250ml油量以下液压工具使用 Use of hydraulic tools with oil volume less than 250ml
包装 Package:	塑料箱 (Plastic box)
工具重量 Tool weight:	3.5kg



电池 Battery



充电器 Charger

9.0Ah

超大电容 超长续航

SUPER CAPACITY AND LONG ENDURANCE



背带设计
Strap design



蓝牙功能
Bluetooth function



安全保障
Security

产品特点 / PRODUCT FEATURES

- 本液压系统是根据不锈钢管道，燃气管道、消防管道等用户的技术要求设计、制造的专用液压传动设备。
- 该系统精选了国内优质液压元、辅件。
- 液压回路采用了集成油路块式结构，液压系统总体结构先进、合理、可靠、易于各项管道系统可靠压接。
- The hydraulic system is a special hydraulic transmission equipment designed and manufactured according to the technical requirements of users such as stainless steel pipes, gas pipes, fire pipes, etc.
- The system has selected domestic high-quality hydraulic elements and accessories.
- The hydraulic circuit adopts an integrated oil circuit block structure, and the overall structure of the hydraulic system is advanced, reasonable, reliable, and easy to reliably crimp various pipeline systems.

EBS-2000

充电式电动液压泵

CHARGING TYPE ELECTRIC HYDRAULIC PUMP

功能可选：

Optional functions：

蓝牙APP远程控制
Bluetooth remote control

遥控器控制
Remote control



不同功能满足不同需求

Different functions meet different needs

- ▶ **EBS-2000** (标准款)
(Standard payment)
- ▶ **EBS-2000-B** (带遥控功能)
(With remote control function)
- ▶ **EBS-2000-C** (带遥控功能+可调压力功能)
(With remote control function + adjustable pressure function)

技术参数 / TECHNICAL DATA:

压接力 Crimping force:	700Mpa(700Bar)
储油量 Oil Reserve:	1500ml
功率 Power:	950w
标配电池 Standard battery:	18V / 9.0Ah 锂电池 18V / 9.0Ah lithium battery
标配充电器 Standard charger:	AC 100V~240V 50~60Hz
启动工作方式 Start working mode:	手动开关+遥控器控制+压接力调节控制 Manual switch+remote control+crimping force adjustment control
适用范围 Scope of application:	1200ml 油量以下液压工具使用 Use of hydraulic tools with oil volume less than 1200ml
排量 Displacement:	高压0.5L/min ; 低压3.5L/min High pressure 0.5L/min; Low pressure 3.5L/min
工具重量 Tool weight:	9.8kg



电池 Battery



充电器 Charger



便携轻巧

高效作业

LIGHT & EFFICIENT

性能稳定可靠 性价比高

Stable performance, high cost performance



镀镍防锈压模
Nickel plated anti rust die



安全保障
Security



应用广泛
Widely used



经济实惠
Affordable

EA-1525 (经济型) (ECONOMICAL)

EMEADS[®]
ZHEJIANG EMEADS TOOLS CO.,LTD

充电式液压卡压工具

CHARGING TYPE HYDRAULIC CLAMPING TOOL

随时随地 无线束缚

WIRELESS BONDAGE, ANYTIME, ANYWHERE

适用于卡压不锈钢水管，消防碳钢管道、
燃气碳钢管道、多层复合管

The tool is applicable to stainless steel pipe, fire carbon steel pipe,
gas carbon steel pipe and multi-layer composite pipe



铜管
Copper tube



多层复合管
Multilayer
composite tube



PEX管
PEX pipe



不锈钢管
Stainless steel pipe



碳钢管
Carbon steel pipe



电池 Battery



充电器 Charger



压模 Mold

技术参数 / TECHNICAL DATA:

卡压范围 Compression range:	12-28mm(1/2"-1") 薄壁不锈钢管 12-35mm(1/2"-1") 薄壁紫铜管 12-32mm 塑料管、铝塑复合管 12-28mm (1/2"-1") thin-wall stainless steel pipe 12-35mm (1/2"-1") thin-wall copper tube 12-32mm Plastic pipe, aluminum plastic composite pipe	标配电池 Standard battery:	18V / 4.0Ah 锂电池 18V / 4.0Ah lithium battery
注意: 不同管件类型及材质, 卡压范围会有所变化, 具体应根据配套管件而定 Note: different pipe type and material, compression range will change, should be based on the specific supporting pipe		标配充电器 Standard charger:	AC 100V~240V 50~60Hz
额定出力 Rated output:	19KN	电池充电时间 Battery charging time:	约2小时 (About 2 hours)
行程 Trip:	30mm	保养周期 Maintenance cycle:	30000次(times)
单次卡压耗时 Time consumption of single clamping:	2-4s	每饱和电池卡压次数 Number of stuck voltage per saturated battery:	180次 (DN20不锈钢管接头) 180 times (DN20 stainless steel pipe joint)
配件 / ACCESSORIES:		毛重 Gross weight:	3.5kg
电池 Battery:	2 pieces	工具尺寸 Tool dimensions:	363x120x75mm
充电器 Charger:	1 piece	模具配置 Mold configuration:	15, 20, 25mm

配件 / ACCESSORIES:

电池 Battery:	2 pieces	充电器 Charger:	1 piece	模具配置 Mold configuration:	15, 20, 25mm
-------------	----------	--------------	---------	--------------------------	--------------



便携轻巧 高效作业

LIGHT & EFFICIENT

性能稳定可靠 性价比高

Stable performance, high cost performance



镀镍防锈压模
Nickel plated anti rust die



安全保障
Security



应用广泛
Widely used



经济实惠
Affordable

EA-1550 (经济型) (ECONOMICAL)

EMEADS[®]
ZHEJIANG EMEADS TOOLS CO.,LTD

充电式液压卡压工具

CHARGING TYPE HYDRAULIC CLAMPING TOOL

随时随地 无线束缚

WIRELESS BONDAGE, ANYTIME, ANYWHERE

适用于卡压不锈钢水管、铜管、 多层复合管

The tool is applicable to clamping stainless steel water pipe, copper pipe and multi-layer composite pipe



铜管
Copper tube



多层复合管
Multilayer
composite tube



PEX管
PEX pipe



不锈钢管
Stainless steel pipe



电池 Battery



充电器 Charger



压模 Mold

技术参数 / TECHNICAL DATA:

卡压范围

Compression range:

12-54mm(1/2"-2") 薄壁不锈钢管、塑料管、铝塑复合管、铜管
12-54mm (1/2"-2") Thin-wall stainless steel pipe, Plastic pipe, aluminum plastic composite pipe, copper pipe

注意: 不同管件类型及材质, 卡压范围会有所变化, 具体应根据配套管件而定
Note: different pipe type and material, compression range will change, should be based on the specific supporting pipe

额定出力 Rated output:

32KN (活塞出力 Piston output)

行程 Trip:

40mm

单次卡压耗时

Time consumption of single clamping:

3-4.5s (根据管件的直径)
3-4.5s (According to the diameter of the pipe fitting)

标配电池 Standard battery:

18V / 4.0Ah 锂电池
18V / 4.0Ah lithium battery

标配充电器 Standard charger:

AC 100V~240V 50~60Hz

电池充电时间 Battery charging time:

约2小时 (About 2 hours)

保养周期 Maintenance cycle:

30000次(times)

每饱和电池卡压次数

Number of stuck voltage per saturated battery:

约350次 (DN20)
About 350 times (DN20)

重量 Weight:

3.9kg (工具带电池)
6.1kg (工具带电池和一副卡钳)
3.9kg (tool with battery)
6.1kg (tool with battery and a pair of calipers)

工具尺寸 Tool dimensions:

450x81x128mm

配件 / ACCESSORIES:

电池 Battery:

2 pieces

充电器 Charger:

1 piece

模具配置 Mold configuration:

15, 20, 25, 32, 40, 50mm



便携轻巧 高效作业

LIGHT & EFFICIENT

性能稳定可靠 性价比高

Stable performance, high cost performance



镀镍防锈压模
Nickel plated anti rust die



安全保障
Security



应用广泛
Widely used



经济实惠
Affordable

EA-1550R (经济型) (ECONOMICAL)

EMEADS[®]
ZHEJIANG EMEADS TOOLS CO.,LTD

充电式液压卡压工具

CHARGING TYPE HYDRAULIC CLAMPING TOOL

随时随地 无线束缚

WIRELESS BONDAGE, ANYTIME, ANYWHERE

适用于卡压不锈钢水管、铜管、 多层复合管

The tool is applicable to clamping stainless steel water pipe, copper pipe and multi-layer composite pipe



不锈钢环压接头
Stainless steel ring
compression joint



不锈钢管
Stainless steel pipe



多层复合管
Multilayer
composite tube



铜管
Copper tube



电池 Battery



充电器 Charger



压模 Mold

技术参数 / TECHNICAL DATA:

卡压范围 Compression range:	12-54mm(1/2"-2") 薄壁不锈钢管、塑料管、铝塑复合管、铜管 12-54mm (1/2"-2") Thin-wall stainless steel pipe, Plastic pipe, aluminum plastic composite pipe, copper pipe	标配电池 Standard battery:	18V / 4.0Ah 锂电池 18V / 4.0Ah lithium battery
注意: 不同管件类型及材质, 卡压范围会有所变化, 具体应根据配套管件而定 Note: different pipe type and material, compression range will change, should be based on the specific supporting pipe		标配充电器 Standard charger:	AC 100V~240V 50~60Hz
额定出力 Rated output:	32KN (活塞出力 Piston output)	电池充电时间 Battery charging time:	约2小时 (About 2 hours)
行程 Trip:	40mm	保养周期 Maintenance cycle:	30000次(times)
单次卡压耗时 Time consumption of single clamping:	3-4.5s (根据管件的直径) 3-4.5s (According to the diameter of the pipe fitting)	每饱和电池卡压次数 Number of stuck voltage per saturated battery:	约350次 (DN20) About 350 times (DN20)
配件 / ACCESSORIES:		重量 Weight:	3.9kg (工具带电池) 6.1kg (工具带电池和一副卡钳) 3.9kg (tool with battery) 6.1kg (tool with battery and a pair of calipers)
电池 Battery:	2 pieces	工具尺寸 Tool dimensions:	450x81x128mm
充电器 Charger:	1 piece	模具配置 Mold configuration:	15, 20, 25, 32, 40, 50mm



便携轻巧 高效作业

LIGHT & EFFICIENT



镀镍防锈压模
Nickel plated anti rust die



安全保障
Security



应用广泛
Widely used



经济实惠
Affordable

将碳钢管表面涂层损伤降到最低！
Minimize coating damage on carbon steel pipes!

EA-1550Q (经济型) (ECONOMICAL)

EMEADS[®]
ZHEJIANG EMEADS TOOLS CO.,LTD

充电式液压卡压工具

CHARGING TYPE HYDRAULIC CLAMPING TOOL

随时随地 无线束缚

WIRELESS BONDAGE, ANYTIME, ANYWHERE

专用于消防碳钢管道、燃气碳钢管道环压
最新技术方案。

It is specially used for the latest technical scheme of carbon steel pipeline for fire protection and carbon steel pipeline for gas.



铜管
Copper tube



燃气管道
Gas pipeline



消防管道
Fire fighting pipeline



电池 Battery



充电器 Charger



压模 Mold

技术参数 / TECHNICAL DATA:

卡压范围 Compression range:	12-54mm(1/2"-2") 碳钢管、薄壁不锈钢管、塑料管、铝塑复合管、铜管 12-54mm (1/2"-2") Carbon steel pipe, thin-wall stainless steel pipe, plastic pipe, aluminum plastic composite pipe, copper pipe	标配电池 Standard battery:	18V / 4.0Ah 锂电池 18V / 4.0Ah lithium battery
注意: 不同管件类型及材质, 卡压范围会有所变化, 具体应根据配套管件而定 Note: different pipe type and material, compression range will change, should be based on the specific supporting pipe		标配充电器 Standard charger:	AC 100V~240V 50~60Hz
额定出力 Rated output:	32KN (活塞出力 Piston output)	电池充电时间 Battery charging time:	约2小时 (About 2 hours)
行程 Trip:	40mm	保养周期 Maintenance cycle:	30000次(times)
单次卡压耗时 Time consumption of single clamping:	3-4.5s (根据管件的直径) 3-4.5s (According to the diameter of the pipe fitting)	每饱和电池卡压次数 Number of stuck voltage per saturated battery:	约350次 (DN20) About 350 times (DN20)
配件 / ACCESSORIES:		重量 Weight:	3.9kg (工具带电池) 6.1kg (工具带电池和一副卡钳) 3.9kg (tool with battery) 6.1kg (tool with battery and a pair of calipers)
电池 Battery:	2 pieces	充电器 Charger:	1 piece
		模具配置 Mold configuration:	15, 20, 25, 32, 40, 50mm
		工具尺寸 Tool dimensions:	450x81x128mm

配件 / ACCESSORIES:

电池 Battery:	2 pieces	充电器 Charger:	1 piece	模具配置 Mold configuration:	15, 20, 25, 32, 40, 50mm
-------------	----------	--------------	---------	--------------------------	--------------------------

便携轻巧 高效作业

LIGHT & EFFICIENT

将碳钢管表面涂层损伤降到最低！

Minimize coating damage on carbon steel pipes!



镀镍防锈压模
Nickel plated anti rust die



安全保障
Security



应用广泛
Widely used



经济实惠
Affordable

EA-15100 (经济型) (ECONOMICAL)

EMEADS[®]
ZHEJIANG EMEADS TOOLS CO.,LTD

充电式液压卡压工具

CHARGING TYPE HYDRAULIC CLAMPING TOOL

适用卡压不锈钢水管,
消防碳钢管道、
燃气碳钢管道、
多层复合管

The tool is applicable to stainless steel pipe, fire carbon steel pipe, gas carbon steel pipe and multi-layer composite pipe



铜管
Copper tube



多层复合管
Multilayer composite tube



PEX管
PEX pipe



不锈钢管
Stainless steel pipe



碳钢管
Carbon steel pipe



电池 Battery



充电器 Charger

不锈钢管道压接套装

STAINLESS STEEL PIPE CRIMPING KIT



燃气/消防环压型套装

GAS/FIRE RING COMPRESSION TYPE SUIT



注: 15-100(可选配压模)

Note: 15-100 (optional pressure die)

技术参数 / TECHNICAL DATA:

卡压范围 Compression range:	12-54mm(1/2"-2") 12-108mm(1/2"-4")	{ 薄壁不锈钢管、消防/燃气碳钢管 } { 塑料管、铝塑复合管、铜管 }
	12-54mm (1/2"-2") 12-108mm (1/2"-4")	{ Thin-wall stainless steel pipe, fire/gas carbon steel pipe } { Plastic pipe, aluminum plastic composite pipe, copper pipe }
注意: 不同管件类型及材质, 卡压范围会有所变化, 具体应根据配套管件而定 Note: different pipe type and material, compression range will change, should be based on the specific supporting pipe		
额定出力 Rated output:	40KN (活塞出力 Piston output)	
行程 Trip:	95mm	
储油量 Oil storage:	250ml	
单次卡压耗时 Time consumption of single clamping:	3-8s (根据管件的直径) 3-8s (According to the diameter of the pipe fitting)	

标配电池 Standard battery:	18V / 4.0Ah 锂电池 18V / 4.0Ah lithium battery
标配充电器 Standard charger:	AC 100V~240V 50~60Hz
电池充电时间 Battery charging time:	约2小时 (About 2 hours)
保养周期 Maintenance cycle:	30000次(times)
每饱和电池卡压次数 Number of stuck voltage per saturated battery:	约360次 (DN20不锈钢管接头) About 360 times(DN20Stainless steel pipe joint)
毛重 Gross weight:	4.3kg
工具尺寸 Tool dimensions:	525x318x86mm

配件 / ACCESSORIES:

电池 Battery:	2 pieces	充电器 Charger:	1 piece	模具配置 Mold configuration:	15, 20, 25, 32, 40, 50, 65, 80, 100mm 不锈钢水管(默认)、燃气管选配、消防管选配
-------------	----------	--------------	---------	--------------------------	--

滑紧扩管 自由切换

FREE REPLACEMENT OF SLIDING EXPANSION TUBE



应用广泛
Widely used



提高效率
High efficiency



安全保障
Security

产品特点 / PRODUCT FEATURES

- 可更换的滑紧模和扩管模，适用于多种管件规格。
- 旋转工作头部（180度）就能简单的完成扩管和滑紧功能切换。
- U形钳口和精密导向滑动模座，管件受力均衡变形小（需管件适配）。
- 多瓣式扩管模，扩管后管口壁厚均匀，滑紧后密封可靠。
- 轻巧型设计，结构零件采用优质航空铝材，保证产品强度的同时使产品重量更轻。
- 核心零件采用通用化、标准化制造，品质更有保障。
- 具备自动滑紧功能，达到最大压力自动释放并使活塞复位，并具备中途手动复位功能。
- LED显示屏，具备电池电量、滑紧次数和故障信息等显示功能。
- 18V高性能锂电池，动力强劲有力，更高的滑紧效率，一次充电可以使用180次以上。
- Replaceable sliding tightening die and expanding die are applicable to various pipe fitting specifications.
- Rotating the working head (180 degrees) can simply complete the switch between expanding and sliding functions.
- U-shaped jaw and precision guide sliding die base, the pipe is evenly stressed and has small deformation (pipe fitting is required).
- Multi petal expanding die, with uniform wall thickness of pipe orifice after expanding, and reliable sealing after sliding.
- Lightweight design, structural parts are made of high-quality aviation aluminum, ensuring product strength and making the product lighter.
- The core parts are manufactured in a universal and standardized way, with more guaranteed quality.
- It has the function of automatic sliding and tightening, which can automatically release the maximum pressure and reset the piston, and has the function of manual reset in the middle.
- LED display screen, with battery power, slip times, fault information and other display functions.
- The 18V high-performance lithium battery has strong power and higher sliding and tightening efficiency. It can be used for more than 180 times at one charge.



GES-1240

充电式液压滑套滑紧工具

CHARGING TYPE HYDRAULIC SLIDING SLEEVE TIGHTENING TOOL

适用PEX/PAP管件滑紧

SUITABLE FOR PEX/PAP PIPE FITTING SLIPPING

本工具主要应用于PEX管（交联聚乙烯塑料管）、PAP管（铝塑复合管）等管道系统，冷扩滑套紧箍式管件的滑紧。

This tool is mainly used for the sliding and tightening of cold expanded sliding sleeve clamp type pipe fittings in PEX pipe (cross-linked polyethylene plastic pipe), PAP pipe (aluminum plastic composite pipe) and other pipe systems.

便携轻巧 长久不累

PORTABLE AND EASY



技术参数 / TECHNICAL DATA

额定出力 Rated output:	20 KN
滑紧模具 Sliding die:	16,20,25,32mm
扩管范围 Pipe expansion range:	PEX: Φ 16-20, Φ 25, Φ 32mm PAP: Φ 16, Φ 20, Φ 25mm(根据管件可选配)
每个饱和电池的按压次数 The number of pressing times per saturable battery:	320 times
按下一次 Pressing one time:	3-10 s
电池电压/电容 Battery voltage / capacitance:	18V / 4.0 Ah
毛重 Gross weight:	4.5 kg
标配充电器 Standard charger:	AC 100V~240V 50~60Hz
电池充电时间 Battery charging time:	约2小时 (About 2 hours)
包装 Packing:	塑料盒 Plastic box

配件 / ACCESSORIES:

模具 Mold:	16-22,25-32mm
电池 Battery:	2 pieces
充电器 Charger:	1 piece



电池 Battery



充电器 Charger



无火连接 安全便携

FIRELESS CONNECTION, SAFE AND PORTABLE



安全保障
Security



提高效率
High efficiency

产品特点 / PRODUCT FEATURES

- 可更换的径向插入式滑紧模，适用于多种管件规格。
- 滑紧模可垂直或水平方插入安装，适用于狭小的空间场合。
- U形钳口和精密导向滑动模座，管件受力均匀变形小(需管件适配)。
- Replaceable radial plug-in sliding die, applicable to various pipe fitting specifications.
- The sliding die can be inserted vertically or horizontally, and is suitable for narrow space.
- U-shaped jaw and precision guide sliding die base, the pipe fittings are evenly stressed and have small deformation (fitting of pipe fittings is required).

GES-4523

充电式液压滑紧工具

CHARGING HYDRAULIC SLIDING TOOL

冷媒管道滑紧神器

REFRIGERANT PIPE TIGHTENING DEVICE

主要应用于空调、冰箱、热泵等冷媒管道的滑紧式管件滑紧。其主要应用特点是代替传统焊接工艺，实现“无火连接”。

It is mainly used for the sliding and tightening of refrigerant pipes such as air conditioners, refrigerators and heat pumps. Its main application feature is to replace the traditional welding process to achieve "fire free connection".

便携轻巧 长久不累

PORTABLE AND EASY



压模
Mold



技术参数 / TECHNICAL DATA

额定出力 Rated output:	45 KN
活塞行程 Piston stroke:	23mm
使用范围 Scope of use:	6.35-38.1紫铜管 6.35-38.1Purple copper pipe
滑紧时间 Slip tightening time:	3-8 s
电池电压/电容 Battery voltage / capacitance:	18V / 4.0 Ah
标配充电器 Standard charger:	AC 100V~240V 50~60Hz
电池充电时间 Battery charging time:	约2小时 (About 2 hours)
包装 Packing:	塑料盒 Plastic box
毛重 Gross weight:	4.0 kg
配件 / ACCESSORIES:	
电池 Battery:	2 pieces
充电器 Charger:	1 piece
压模可选配 Optional die: 6.35, 9.52, 12.7, 15.88, 19.05, 22.2, 25.4, 28.6, 34.9, 38.1mm	



电池 Battery



充电器 Charger

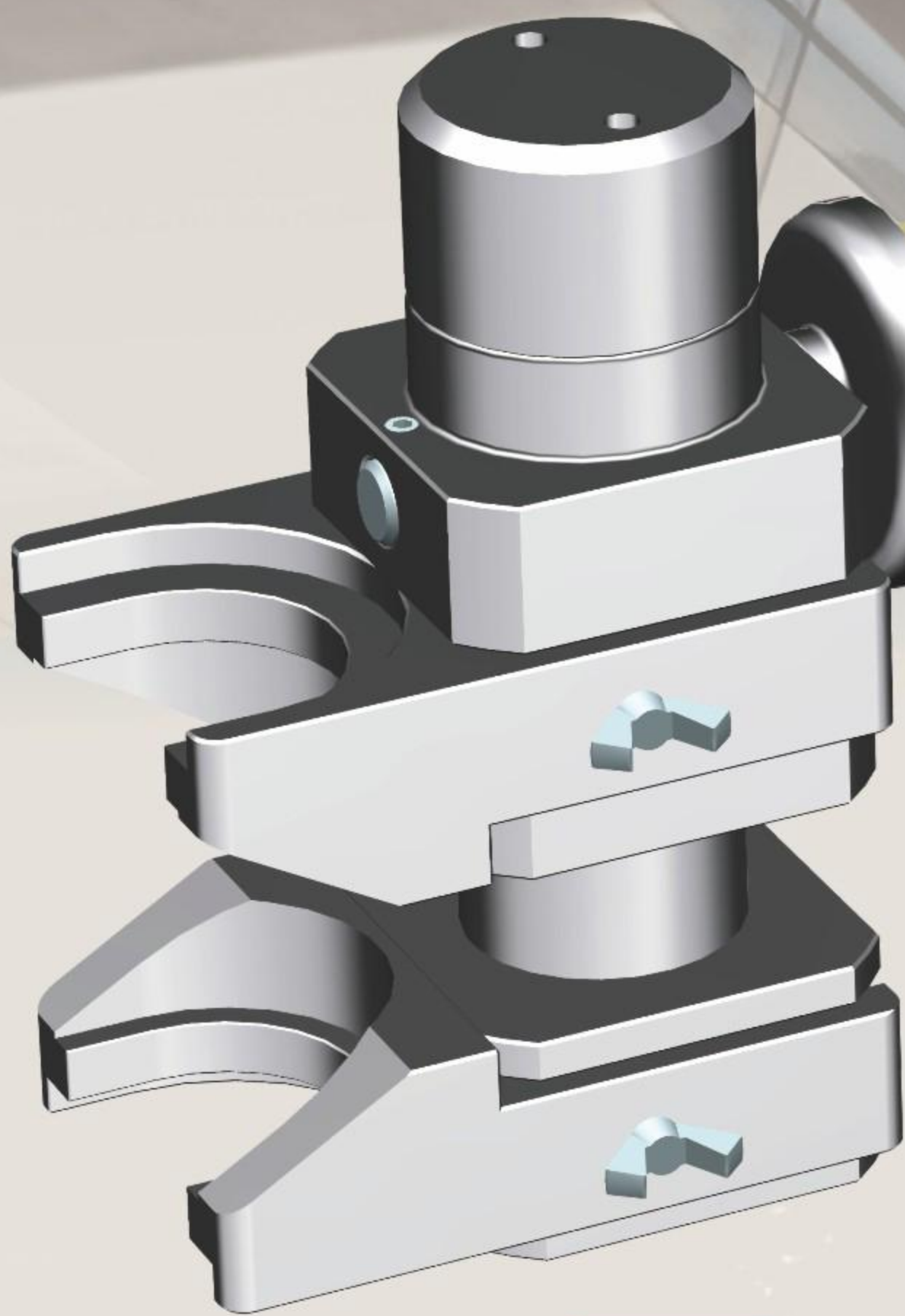

无火连接 安全便携

**FIRELESS CONNECTION,
SAFE AND PORTABLE**



安全保障
Security



提高效率
High efficiency

产品特点 / PRODUCT FEATURES

- 可更换的径向插入式滑紧模，适用于多种管件规格。
- 滑紧模可垂直或水平方插入安装，适用于狭小的空间场合。
- U形钳口和精密导向滑动模座，管件受力均匀变形小(需管件适配)。
- Replaceable radial plug-in sliding die, applicable to various pipe fitting specifications.
- The sliding die can be inserted vertically or horizontally, and is suitable for narrow space.
- U-shaped jaw and precision guide sliding die base, the pipe fittings are evenly stressed and have small deformation (fitting of pipe fittings is required).

YQK-4523

手动式液压滑紧工具

MANUAL HYDRAULIC SLIDING TOOL

冷媒管道滑紧神器

REFRIGERANT PIPE TIGHTENING DEVICE

主要应用于空调、冰箱、热泵等冷媒管道的滑紧式管件滑紧。其主要应用特点是代替传统焊接工艺，实现“无火连接”。

It is mainly used for the sliding and tightening of refrigerant pipes such as air conditioners, refrigerators and heat pumps. Its main application feature is to replace the traditional welding process to achieve "fire free connection".

便携轻巧 长久不累

PORTABLE AND EASY

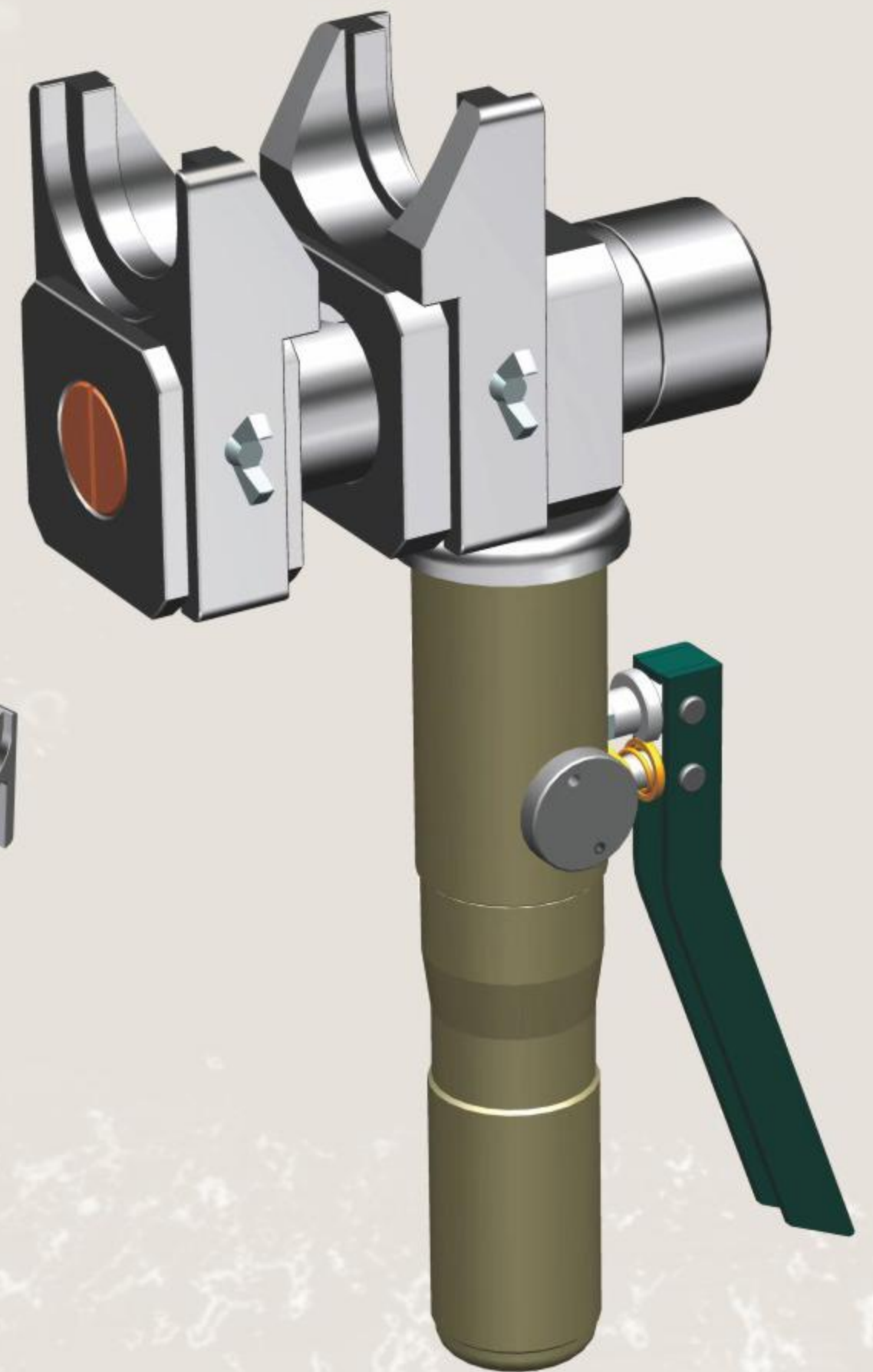

技术参数 / TECHNICAL DATA

额定出力 Rated output:	45 KN
活塞行程 Piston stroke:	23mm
使用范围 Scope of use:	6.35-38.1紫铜管 6.35-38.1Purple copper pipe
滑紧时间 Slip tightening time:	3-8 s
包装 Packing:	塑料盒 Plastic box
毛重 Gross weight:	1.5 kg

配件 / ACCESSORIES:

压模可选配 Optional die: 6.35, 9.52, 12.7, 15.88, 19.05, 22.2, 25.4, 28.6, 34.9, 38.1mm



HT-1550

技术参数 / TECHNICAL DATA

额定输出 Rated output:	32KN
额定工作压力 Rated working pressure:	52Mpa
活塞行程 Piston stroke:	40mm
工作环境温度 Working environment temperature:	-10°C ~ 40°C

配件 ACCESSORIES:

模具配置 Mold configuration:	15, 20, 25, 32, 40, 50mm
--------------------------	--------------------------

选配压模 OPTIONAL DIE



1550型 可选压模套装
Model 1550 optional die set



1550R型 可选压模套装
Model 1550R optional die set



铜管
Copper tube



多层复合管
Multilayer
composite tube



PEX管
PEX pipe



不锈钢管
Stainless steel pipe

HT-1632



技术参数 / TECHNICAL DATA

压接范围 Crimping range:	Φ16-32mm
出力 Force:	60KN
行程 Stroke:	17mm
长度 Length:	460mm
重量 Weight:	3.3kg
包装 Packing:	铁盒 Iron box

配件 ACCESSORIES:

模具配置 Mold configuration:	16, 20, 25, 32mm
--------------------------	------------------



Type TH



Type SV



Type U

手动式液压管件工具 MANUAL HYDRAULIC PIPE FITTINGS TOOL

EMEADS[®]
ZHEJIANG EMEADS TOOLS CO.,LTD

FT-1240



技术参数 / TECHNICAL DATA

压接范围 Crimping range:	Φ16-20, 25-32mm
扩展范围 Expander range:	Φ16-32mm
剪切范围 Shear range:	Maximum to Φ40mm
重量 Weight:	5.2kg
行程 Stroke:	40mm
包装 Packing:	塑料盒 Plastic box

配件 ACCESSORIES:

冲压模具 Pressing mold: Φ16X2.2, Φ20X2.8, Φ25X3.5, Φ32X4.4
胀管模具 Tube expansion mold: Φ16X2.2, Φ20X2.8, Φ25X3.5, Φ32X4.4

FT-1218



技术参数 / TECHNICAL DATA

压力管范围 Pressure tube range:	Φ12-Φ18mm
最大行程 Maximum stroke:	120mm

配件 ACCESSORIES:

冲压模具 Pressing mold: Φ12, 16, 18mm

FT-1225

欧式管工具
European style pipe tool



技术参数 / TECHNICAL DATA

压力管范围 Pressure tube range:	Φ12-Φ25mm
最大行程 Maximum stroke:	80mm

配件 ACCESSORIES:

冲压模具 Pressing mold: Φ12, 16, 20mm

ETM-20/ETM-32

扩散器
Diffuser



型号 Model No:	ETM-20	ETM-32
扩展范围 Expansion range:	Φ16, Φ20, Φ25mm	Φ16, Φ20, Φ25, Φ32mm
产品长度 Product length:	160mm	180mm
产品重量 Product weight:	0.33kg	0.58kg

手动式液压管件工具 MANUAL HYDRAULIC PIPE FITTINGS TOOL

FT-1632

压力管工具
Pressure pipe tool



技术参数 / TECHNICAL DATA

压力管范围 Pressure tube range:	Φ 16-Φ 32mm
最大行程 Maximum stroke:	150mm

配件 ACCESSORIES:

冲压模具 Pressing mold: Φ16, 20, 22, 25mm

FT-1632A

压力管工具
Pressure pipe tool



技术参数 / TECHNICAL DATA

压力管范围 Pressure tube range:	Φ 16-Φ 32mm
最大行程 Maximum stroke:	150mm

配件 ACCESSORIES:

冲压模具 Pressing mold: Φ16, 20, 25, 30mm

FT-1632B

压力管工具
Pressure pipe tool



技术参数 / TECHNICAL DATA

压力管范围 Pressure tube range:	Φ 16-Φ 32mm
最大行程 Maximum stroke:	150mm

配件 ACCESSORIES:

冲压模具 Pressing mold: Φ16, 20, 22, 25mm

FT-1632C

欧式管工具
European style pipe tool



技术参数 / TECHNICAL DATA

压力管范围 Pressure tube range:	Φ 16-Φ 32mm
最大行程 Maximum stroke:	150mm
材料 Material Science:	铝合金 Aluminium alloy

配件 ACCESSORIES:

冲压模具 Pressing mold: Φ16, 20, 22, 25mm

TE-1632

扩散器
Diffuser

手柄由高强度铝合金精密锻造而成，外形美观，重量轻，减轻了劳动强度，质量好，使用寿命长。
The handle is made of high strength aluminum alloy precision forging, with beautiful appearance and light weight, reducing labor intensity, good quality and long service life.



技术参数 / TECHNICAL DATA

扩展范围 Expander range:	Φ 16-Φ 32mm
模具配置 Mold configuration:	Φ 16-20, Φ 25, Φ 32mm
长度 Length:	395mm
重量 Weight:	1.33kg

PE-1632

扩散器
Diffuser



技术参数 / TECHNICAL DATA

扩展范围 Expander range:	Φ 16, Φ 20, Φ 25, Φ 32mm
材料 Material Science:	铝合金 Aluminium alloy
长度 Length:	395mm
重量 Weight:	2.12kg

手动式液压管件工具 MANUAL HYDRAULIC PIPE FITTINGS TOOL



手动式液压管件工具

MANUAL HYDRAULIC PIPE FITTINGS TOOL

JT-1632

手动压管钳 Manual pipe pressing tool

1. 压力模块可更换，更换方便快捷。
 2. 杠杆式二段角力手柄，小号管件可一次到位，大号管件压下时，角度可轻松划分。
 3. 棘爪搭扣是为了确保每个压力都准确到位。
1. Replaceable pressure module, which is convenient and quick to replace
 2. The lever type double segment Angle force handle, the small size pipe fitting can be in place once, When the large size pipe fitting is pressed, the Angle can be divided easily
 3. The pawl clasp is to ensure that each pressure is in place accurately



型号 Model No:	JT-1632
输出 Output:	40KN
行程 Stroke:	16mm
配件 ACCESSORIES:	
SV型 SV type:	Φ16mm, 20mm, 25mm
U型 U type:	Φ16mm, 20mm, 25mm, 32mm
TH型 TH type:	Φ16mm, 20mm, 26mm, 32mm
注意：选择上述模具之一。 Note: one of the above dies is selected.	

JT-1632B

手动压管钳 Manual pipe pressing tool

1. 压力模块可更换，更换方便快捷。
 2. 小号管件可一次到位，大号管件压下时，角度可轻松划分。
 3. 棘爪搭扣是为了确保每个压力都准确到位。
1. Replaceable pressure module, which is convenient and quick to replace
 2. The lever type double segment Angle force handle, the small size pipe fitting can be in place once, When the large size pipe fitting is pressed, the Angle can be divided easily
 3. The pawl clasp is to ensure that each pressure is in place accurately



型号 Model No:	JT-1632B
重量 Weight:	3.00kg
长度 Length:	566mm
配件 ACCESSORIES:	
U型 U type:	Φ16mm, 20mm, 25mm, 32mm
TH型 TH type:	Φ16mm, 20mm, 26mm, 32mm
包装 Packing:	塑料盒 plastic box
注意：选择上述模具之一，也可以定制模具。 Note: One of the above dies is selected, also moulds can be customized.	

JT-1626

手动压管钳 Manual pipe pressing tool

1. 棘轮锁定式压力连接可确保每个接头的准确可靠性和良好的密封性。
 2. 精密冲压钣金和精湛的热处理工艺，提供强大的安全压力连接性能。
 3. 快速转移模具，适用于最大至20mm的不同尺寸的管件。
 4. 防滑手柄结构，压制过程更加舒适。
1. Ratchet locking type pressure connection ensures the accurate reliability and good sealing of each joint.
 2. Precision stamping sheet metal and exquisite heat treatment process, providing strong safety pressure connection performance.
 3. Fast transfer die, suitable for different sizes of pipe fitting maximum to 20mm.
 4. Antiskid handle structure, the pressing process is more comfortable.



型号 Model No:	JT-1626
重量 Weight:	2.1kg
长度 Length:	467mm
配件 ACCESSORIES:	
U型 U type:	Φ16mm, 20mm, 25mm
包装 Packing:	塑料盒 plastic box
注意：由于管件不同，请在订货前确认标准尺寸。 Note: Because of the different pipe fittings, please confirm the standard size before the order.	

PS-1632A 倒角机 Chamfering tool



PS-1632B 倒角机 Chamfering tool



型号 Model No:	PS-1632A / PS-1632B
特征 Features:	适用于多层复合管和PEX管的毛边角 It is suitable for the burr Angle of multi-layer compound tube and PEX tube
倒角范围 Chamfering range:	Φ16, 20, 26, 32mm

卡压式管件承口的结构与尺寸

STRUCTURE AND SIZE OF CLAMP TYPE PIPE FITTING SOCKET

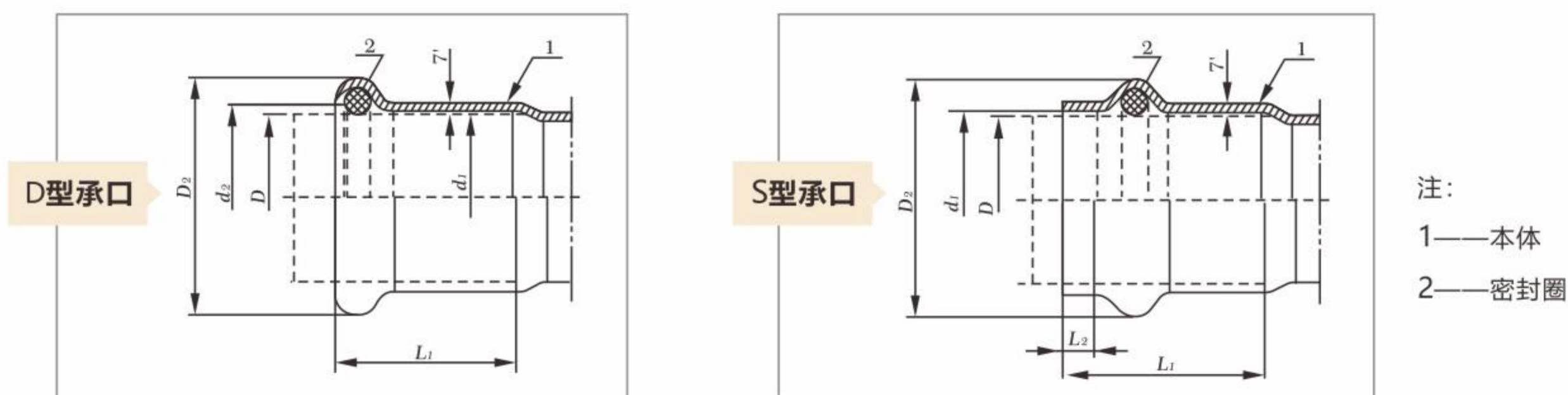

注：
1——本体
2——密封圈

GB/T 19228.1-2011

D型管件承口的基本尺寸

单位：mm

公称尺寸 DN	管子外径 D		管件壁厚 T_{min}		承口内径 d_1		承口端内径 d_2		承口端外径 D_2		承口长度 L_1	
	I 系列	II 系列	I 系列	II 系列	I 系列	II 系列	I 系列	II 系列	I 系列	II 系列	I 系列	II 系列
10	—	12.7	—	0.6	—	$12.8^{+0.4}$	—	13.3 ± 0.3	—	18.2 ± 0.3	—	21 ± 3
15	18	15.9	1.2	0.6	$18.2^{+0.5}$	$16.1^{+0.4}$	18.9 ± 0.4	16.6 ± 0.3	26.2 ± 0.4	22.2 ± 0.3	20 ± 3	21 ± 3
20	22	22.2	1.2	0.8	$22.2^{+0.5}$	$22.3^{+0.4}$	23.0 ± 0.4	22.8 ± 0.3	31.6 ± 0.4	30.1 ± 0.3	21 ± 3	24 ± 3
25	28	28.6	1.2	0.8	$28.2^{+0.5}$	$28.7^{+0.4}$	28.9 ± 0.4	29.2 ± 0.3	37.2 ± 0.4	36.4 ± 0.3	23 ± 3	24 ± 3
32	35	34.00	1.2	1.0	$35.3^{+0.8}$	$34.3^{+0.6}$	36.5 ± 0.6	36.6 ± 0.4	44.3 ± 0.6	45.4 ± 0.4	26 ± 4	39 ± 4
40	42	42.70	1.2	1.0	$42.3^{+0.8}$	$43.0^{+0.6}$	43 ± 0.6	46.0 ± 0.4	53.3 ± 0.6	56.2 ± 0.4	30 ± 4	47 ± 4
50	54	48.6	1.2	1.0	$54.4^{+0.8}$	$49.0^{+0.6}$	55.0 ± 0.6	52.4 ± 0.4	65.4 ± 0.6	63.2 ± 0.4	35 ± 4	52 ± 4
60	—	60.3	—	1.3	—	$61.0^{+1.0}$	—	64.3 ± 0.5	—	77.3 ± 0.5	—	52 ± 4
65	76.1	—	1.5	—	$76.70^{+1.5}$	—	78.0 ± 1.0	—	94.7 ± 1.0	—	53 ± 5	—
80	88.9	—	1.5	—	$89.50^{+1.5}$	—	91.0 ± 1.0	—	109.5 ± 1.0	—	60 ± 5	—
100	108.0	—	1.5	—	$108.8^{+1.5}$	—	111.0 ± 1.0	—	132.8 ± 1.0	—	75 ± 5	—



S型管件承口的基本尺寸

单位：mm

公称尺寸 DN	管子外径 D		管件壁厚 T_{min}	承口内径 d_1		承口端外径 D_2		承口长度 L_1
	I 系列	II 系列		I 系列	II 系列	I 系列	II 系列	
10	12.7	—	0.6	$12.8^{+0.2}$	—	18.2 ± 0.2	—	18 ± 2
15	16	(15.9)	0.6	$16.2^{+0.3}$	$16.1^{+0.3}$	22.2 ± 0.2	22.2 ± 0.3	23 ± 3
20	20	22.2	0.8	$20.2^{+0.3}$	$22.3^{+0.3}$	27.9 ± 0.2	30.1 ± 0.3	26 ± 3
25	25.4	28.6	0.8	$25.6^{+0.3}$	$28.7^{+0.3}$	33.8 ± 0.2	36.4 ± 0.3	32 ± 3
32	32	34.0	1.0	$32.3^{+0.4}$	$34.3^{+0.4}$	44.0 ± 0.3	45.4 ± 0.4	38 ± 3
40	40	42.7	1.0	$40.3^{+0.4}$	$43.1^{+0.4}$	53.5 ± 0.3	56.2 ± 0.4	46 ± 4
50	50.8	—	1.0	$51.2^{+0.5}$	—	66.5 ± 0.3	—	56 ± 4
60	63.5	—	1.3	$63.9^{+0.5}$	—	79.30 ± 0.3	—	58 ± 4
65	76.1	—	1.5	$76.7^{+1.2}$	—	94.7 ± 0.8	—	60 ± 5
80	88.9	—	1.5	$89.50^{+1.2}$	—	109.5 ± 0.8	—	70 ± 5
100	101.6	—	1.5	$102.20^{+1.2}$	—	126.40 ± 0.8	—	82 ± 5



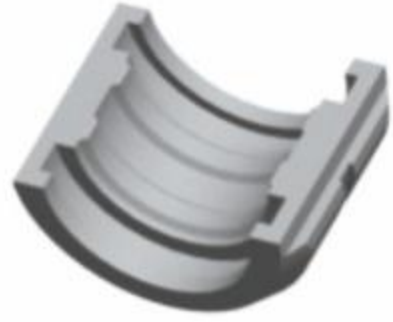
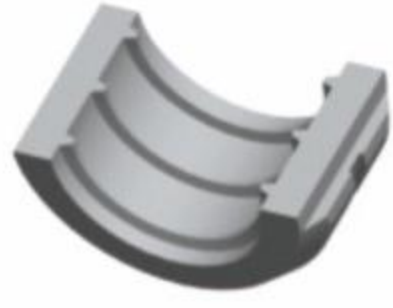
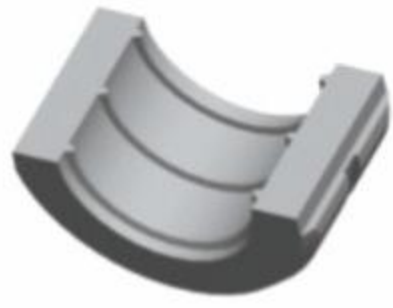
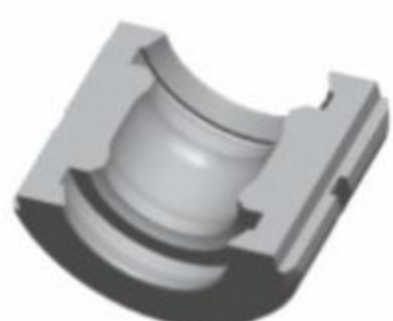
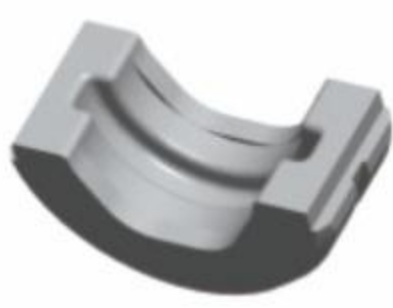
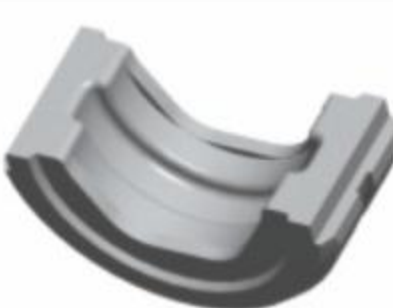
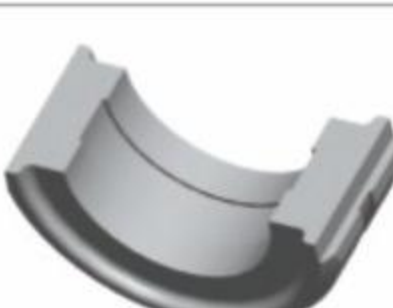
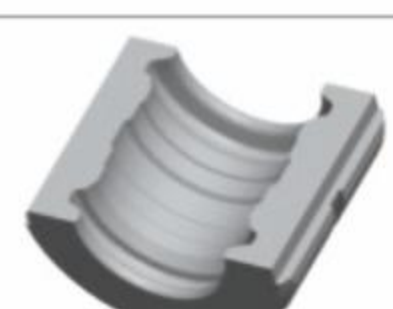
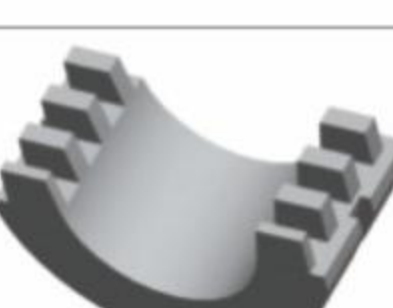







注：推荐优先选用 I 系列；带括号尺寸不推荐使用。

压接模具 CRIMPING MOLD

	TH Type		
	Die Size	Die Size	Art No.
	TH 16	16mm	800890
	TH 20	20mm	800900
	TH 26	26mm	800910
	TH 32	32mm	800920
	U Type		
	Die Size	Die Size	Art No.
	U 16	16mm	800930
	U 20	20mm	800940
	U 25	26mm	800950
	U 32	32mm	800960
	H Type		
	Die Size	Die Size	Art No.
	H 16	16mm	800970
	H 20	20mm	800980
	H 25	26mm	800990
	H 32	32mm	801000
	B Type		
	Die Size	Die Size	Art No.
	B 16	16mm	801010
	B 20	20mm	801020
	B 26	26mm	801030
	M Type		
	Die Size	Die Size	Art No.
	M 12	12mm	801040
	M 15	15mm	801050
	M 18	18mm	801060
	M 22	22mm	801070
	M 28	28mm	801080
	V Type		
	Die Size	Die Size	Art No.
	V 15	15mm	801090
	V 18	18mm	801100
	V 22	22mm	801110
	V 28	28mm	801120
	VP Type		
	Die Size	Die Size	Art No.
	VP 16	16mm	801130
	VP 20	20mm	801140
	VP 25	25mm	801150
	VP 32	32mm	801160
	G Type		
	Die Size	Die Size	Art No.
	G 16	16mm	801170
	G 20	20mm	801180
	G 26	26mm	801190
	G 32	32mm	801200
	RF Type		
	Die Size	Die Size	Art No.
	RF 12	12mm	801210
	RF 16	16mm	801220
	RF 20	20mm	801230
	RF 25	25mm	801240
	SV Type		
	Die Size	Die Size	Art No.
	SV 15	16mm	801250
	SV 20	20mm	801260
	SV 25	26mm	801270

TH Type				
	燕尾型压模 Dovetail type press die	<input checked="" type="checkbox"/>	Jaw Size	Art No.
			TH 16	800010
	转换模+半圆模 Conversion die + semicircle die	<input checked="" type="checkbox"/>	TH 20	800020
			TH 26	800030
			TH 32	800040
U Type				
	燕尾型压模 Dovetail type press die	<input checked="" type="checkbox"/>	Jaw Size	Art No.
			U 16	800050
	转换模+半圆模 Conversion die + semicircle die	<input checked="" type="checkbox"/>	U 20	800060
			U 25	800070
			U 32	800080
H Type				
	燕尾型压模 Dovetail type press die	<input checked="" type="checkbox"/>	Jaw Size	Art No.
			H 16	800090
	转换模+半圆模 Conversion die + semicircle die	<input checked="" type="checkbox"/>	H 20	800100
			H 25	800110
			H 32	800120
B Type				
	燕尾型压模 Dovetail type press die	<input checked="" type="checkbox"/>	Jaw Size	Art No.
			B 16	800130
	转换模+半圆模 Conversion die + semicircle die	<input checked="" type="checkbox"/>	B 20	800140
			B 26	800150
			B 32	800160
M Type				
	燕尾型压模 Dovetail type press die	<input checked="" type="checkbox"/>	Jaw Size	Art No.
			M 12	800170
	转换模+半圆模 Conversion die + semicircle die	<input checked="" type="checkbox"/>	M 15	800180
			M 18	800190
			M 22	800200
			M 28	800210
			M 35	800220
			M 42	800230
			M 54	800240
V Type				
	燕尾型压模 Dovetail type press die	<input checked="" type="checkbox"/>	Jaw Size	Art No.
			V 15	800250
	转换模+半圆模 Conversion die + semicircle die	<input checked="" type="checkbox"/>	V 18	800260
			V 22	800270
			V 28	800280
			V 35	800290
			V 42	800300
			V 54	800310
VP Type				
	燕尾型压模 Dovetail type press die	<input checked="" type="checkbox"/>	Jaw Size	Art No.
			VP 16	800320
	转换模+半圆模 Conversion die + semicircle die	<input checked="" type="checkbox"/>	VP 20	800330
			VP 25	800340
			VP 32	800350
G Type				
	燕尾型压模 Dovetail type press die	<input checked="" type="checkbox"/>	Jaw Size	Art No.
			G 16	800360
	转换模+半圆模 Conversion die + semicircle die	<input checked="" type="checkbox"/>	G 20	800370
			G 26	800380
			G 32	800390
RF Type				
	燕尾型压模 Dovetail type press die	<input checked="" type="checkbox"/>	Jaw Size	Art No.
			RF 12	800400
	转换模+半圆模 Conversion die + semicircle die	<input checked="" type="checkbox"/>	RF 16	800410
			RF 20	800420
			RF 25	800430
SV Type				
	燕尾型压模 Dovetail type press die	<input checked="" type="checkbox"/>	Jaw Size	Art No.
			SV 15	800440
	转换模+半圆模 Conversion die + semicircle die	<input checked="" type="checkbox"/>	SV 20	800450
			SV 25	800460
			SV 40	800470
			SV 50	800480

压接模具 CRIMPING MOLD

TH Type				
	燕尾型压模 Dovetail type press die	<input checked="" type="checkbox"/>	Jaw Size	Art No.
			TH 16	800490
TH 20	800500			
	转换模+半圆模 Conversion die + semicircle die	<input checked="" type="checkbox"/>	TH 26	800510
			TH 32	800520
U Type				
	燕尾型压模 Dovetail type press die	<input checked="" type="checkbox"/>	Jaw Size	Art No.
			U 16	800530
U 20	800540			
	转换模+半圆模 Conversion die + semicircle die	<input checked="" type="checkbox"/>	U 25	800550
			U 32	800560
H Type				
	燕尾型压模 Dovetail type press die	<input checked="" type="checkbox"/>	Jaw Size	Art No.
			H 16	800570
H 20	800580			
	转换模+半圆模 Conversion die + semicircle die	<input checked="" type="checkbox"/>	H 25	800590
			H 32	800600
B Type				
	燕尾型压模 Dovetail type press die	<input checked="" type="checkbox"/>	Jaw Size	Art No.
			B 16	800610
B 20	800620			
	转换模+半圆模 Conversion die + semicircle die	<input checked="" type="checkbox"/>	B 26	800630
				800640
M Type				
	燕尾型压模 Dovetail type press die	<input checked="" type="checkbox"/>	Jaw Size	Art No.
			M 12	800650
M 15	800660			
	转换模+半圆模 Conversion die + semicircle die	<input checked="" type="checkbox"/>	M 18	800670
			M 22	800680
M 28	800690			
V Type				
	燕尾型压模 Dovetail type press die	<input checked="" type="checkbox"/>	Jaw Size	Art No.
			V 15	800700
V 18	800710			
	转换模+半圆模 Conversion die + semicircle die	<input checked="" type="checkbox"/>	V 22	800720
			V 28	800730
VP Type				
	燕尾型压模 Dovetail type press die	<input checked="" type="checkbox"/>	Jaw Size	Art No.
			VP 16	800740
VP 20	800750			
	转换模+半圆模 Conversion die + semicircle die	<input checked="" type="checkbox"/>	VP 25	800760
			VP 32	800770
G Type				
	燕尾型压模 Dovetail type press die	<input checked="" type="checkbox"/>	Jaw Size	Art No.
			G 16	800780
G 20	800790			
	转换模+半圆模 Conversion die + semicircle die	<input checked="" type="checkbox"/>	G 26	800800
			G 32	800810
RF Type				
	燕尾型压模 Dovetail type press die	<input checked="" type="checkbox"/>	Jaw Size	Art No.
			RF 12	800820
RF 16	800830			
	转换模+半圆模 Conversion die + semicircle die	<input checked="" type="checkbox"/>	RF 20	800840
			RF 25	800850
SV Type				
	燕尾型压模 Dovetail type press die	<input checked="" type="checkbox"/>	Jaw Size	Art No.
			SV 15	800860
SV 20	800870			
	转换模+半圆模 Conversion die + semicircle die	<input checked="" type="checkbox"/>	SV 25	800880

FIRE RESCUE SERIES

消防救援系列

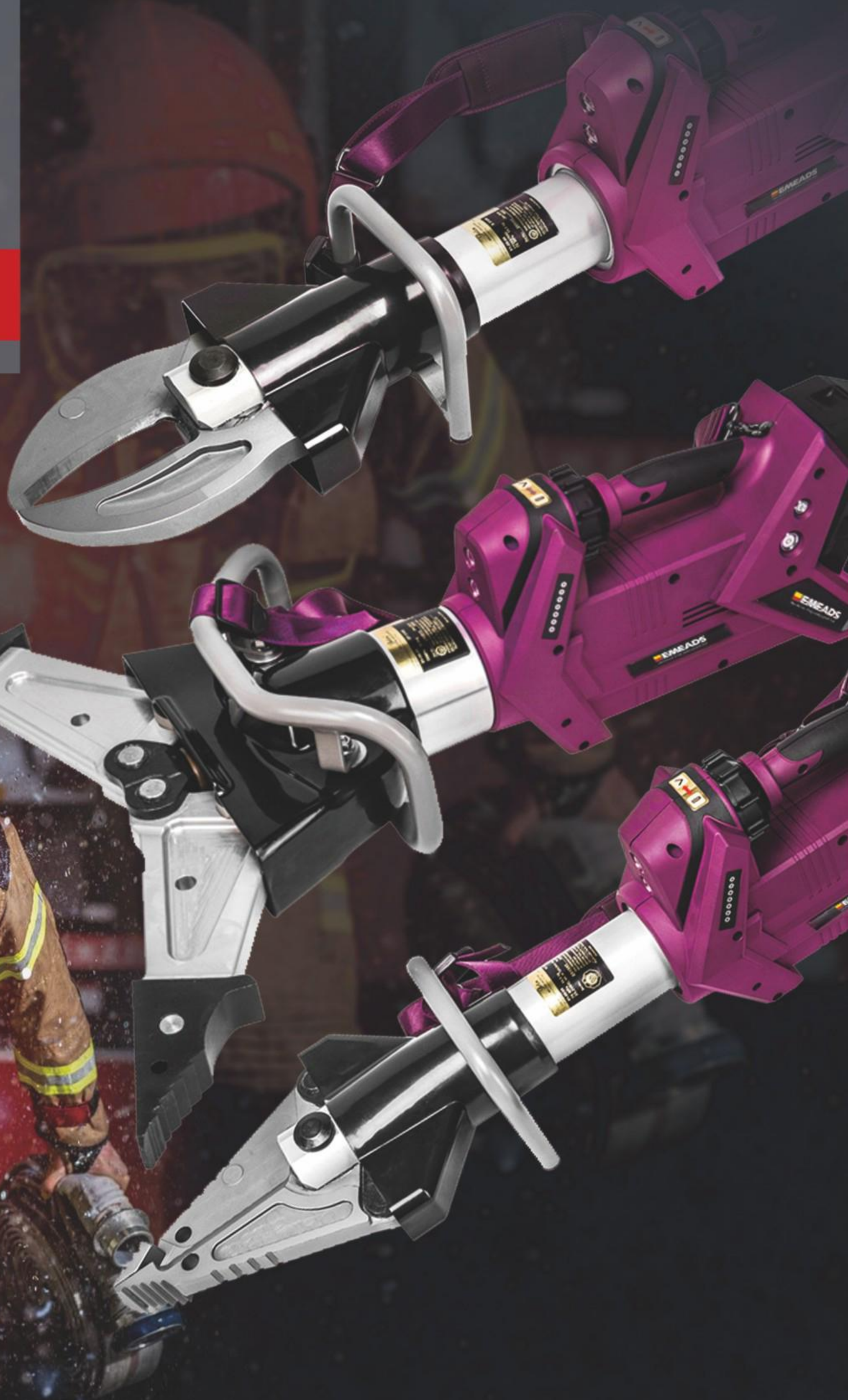

抢险救援 高效可靠

EMERGENCY RESCUE,
EFFICIENT AND RELIABLE

充电式液压切断机 CHARGING HYDRAULIC CUTTING MACHINE

EMEADS[®]
ZHEJIANG EMEADS TOOLS CO., LTD

EBS-16

技术参数 / TECHNICAL DATA

充电器电压 Charger voltage:	100-240VAC
电池电压/容量 Voltage/capacity:	18V/5.0Ah/9.0Ah可选
功率 Wattage:	1500W
净重 Net weight:	5.5kg
切断速度 Cutting speed:	4.0s
最大切割直径 Max rebar:	16 mm
最小切割直径 Min rebar:	4 mm
包装尺寸 Packing size:	580*440*160mm
机器尺寸 Machine size:	360*250*100mm
一次充电切断次数 Number of single cutting	80 times
充电时间 Charging time:	4 hours

配件 ACCESSORIES

电池 Battery:	2pcs	充电器 Charger:	1pc
-------------	------	--------------	-----



EBS-20

技术参数 / TECHNICAL DATA

充电器电压 Charger voltage:	100-240VAC
电池电压/容量 Voltage/capacity:	18V/5.0Ah/9.0Ah可选
功率 Wattage:	1500W
净重 Net weight:	7kg
切断速度 Cutting speed:	5.0s
最大切割直径 Max rebar:	20mm
最小切割直径 Min rebar:	4mm
包装尺寸 Packing size:	580*440*160mm
机器尺寸 Machine size:	378*300*118mm
一次充电切断次数 Number of single cutting	80times
充电时间 Charging time:	4 hours

配件 ACCESSORIES

电池 Battery:	2pcs	充电器 Charger:	1pc
-------------	------	--------------	-----



EBS-25

技术参数 / TECHNICAL DATA

充电器电压 Charger voltage:	100-240VAC
电池电压/容量 Voltage/capacity:	18V/5.0Ah/9.0Ah可选
功率 Wattage:	1500W
净重 Net weight:	10 kg
切断速度 Cutting speed:	5.0s
最大切割直径 Max rebar:	25mm
最小切割直径 Min rebar:	4 mm
包装尺寸 Packing size:	565*230*345mm
机器尺寸 Machine size:	490*145*250 mm
充电时间 Charging time:	4 hours

配件 ACCESSORIES

电池 Battery:	2pcs	充电器 Charger:	1pc
-------------	------	--------------	-----



消防救援系列

FIRE RESCUE SERIES

● **产品特点**

电动破拆工具组是一种先进的无管无火花电动液压破拆工具，本工具组无需担心动力源，采用了军工品质高倍率电池，可在-20-60°的环境下实施作业，方便携带特别适合野外抢险、户外突击、攻坚破拆等作业，适用于军用、警用、消防作业，是继液压破拆组后的一种更为先进的破拆装备。

● **Product features**

The electric demolition tool set is an advanced tubeless and spark free electric hydraulic demolition tool. This tool set does not need to worry about the power source. It uses military high-quality high magnification batteries, which can operate in a - 20-60 ° environment. It is convenient to carry. It is especially suitable for field rescue, outdoor assault, hard demolition and other operations. It is suitable for military, police and fire fighting operations. It is a more advanced demolition equipment after the hydraulic demolition tool set.

SC357-E 电动液压剪扩钳

技术参数 / TECHNICAL DATA

额定压力 Rated pressure:	720bar
牵引力 Tractive force:	48KN
牵引距离 Towing distance:	340mm
最大剪切力 Maximum shear force:	380KN
剪切范围 Cutting range:	Φ32mm圆钢/16mm钢板
最大扩张力 Maximum expansion tension:	58.07K
扩张距离 Spreading distance:	360mm
净重/毛重 Net weight/Gross weight:	20.64/34.4kg
机器尺寸 Machine dimensions:	929x246x287mm
外包尺寸 Outsourcing size:	1100x315x380mm

附件：2电1充/工具包、黑色铝合金包装箱



SC310-E 电动液压扩张器

技术参数 / TECHNICAL DATA

额定压力 Rated pressure:	720bar
液压油量 Hydraulic oil volume:	150cm ³
挤压力 Extrusion force:	144KN
牵引距离 Towing distance:	500mm
最大扩张力 Maximum expansion tension:	73.24KN
扩张距离 Spreading distance:	737mm
最大牵引力 Maximum traction:	56KN
净重/毛重 Net weight/Gross weight:	26.03/40.8kg
机器尺寸 Machine dimensions:	905x255x258mm
外包尺寸 Outsourcing size:	1150x440x380mm

附件：2电1充/工具包、黑色铝合金包装箱



S312-E 电动液压剪切器

技术参数 / TECHNICAL DATA

额定压力 Rated pressure:	720bar
最大剪切力 Maximum shear force:	642KN
剪切范围 Cutting range:	Φ40mm圆钢/16mm钢板
电池 Battery:	DC 28V 5.0Ah
净重/毛重 Net weight/Gross weight:	20.69kg / 35.0kg
开口距离 Opening distance:	163mm
机器尺寸 Machine dimensions:	847X246X287mm
外包尺寸 Outsourcing size:	1100x315x380mm

附件：2电1充/工具包、黑色铝合金包装箱



SC257-E 电动液压剪扩器

技术参数 / TECHNICAL DATA

额定压力 Rated pressure:	720bar
牵引力 Tractive force:	57KN
牵引距离 Towing distance:	228mm
最大剪切力 Maximum shear force:	387KN
剪切范围 Cutting range:	Φ32mm圆钢/16mm钢板
最大扩张力 Maximum expansion tension:	58.07K
扩张距离 Spreading distance:	360mm
电池 Battery:	DC 28V 5.0Ah
净重/毛重 Net weight/Gross weight:	20.64/34.4kg
机器尺寸 Machine dimensions:	1000x260x230mm
外包尺寸 Outsourcing size:	1100x315x380mm



SP210-E 电动液压扩张器

技术参数 / TECHNICAL DATA

额定压力 Rated pressure:	720bar
牵引力 Tractive force:	41KN
牵引距离 Towing distance:	570mm
最大扩张力 Maximum expansion tension:	73.24-308KN
扩张距离 Spreading distance:	737mm
电池 Battery:	DC 28V 5.0Ah
净重/毛重 Net weight/Gross weight:	26.03/40.8kg
机器尺寸 Machine dimensions:	1040x350x260mm
外包尺寸 Outsourcing size:	1150x440x380mm



R412-E 电动液压撑顶器

技术参数 / TECHNICAL DATA

额定压力 Rated pressure:	720bar
活塞行程 Piston stroke:	350mm
撑顶力 Jacking force:	127.35KN
撑顶长范围 Support length range:	540-890mm
电池 Battery:	DC 28V 5.0Ah
净重/毛重 Net weight/Gross weight:	19.79kg / 32.5kg
机器尺寸 Machine dimensions:	597X135X313mm
外包尺寸 Outsourcing size:	665x425x250mm

附件：2电1充/工具包、黑色铝合金包装箱



R320-E 电动液压撑顶器

技术参数 / TECHNICAL DATA

额定压力 Rated pressure:	720bar
撑顶力 Jacking force:	127.35KN
撑顶长范围 Support length range:	540-890mm
活塞范围 Piston range:	350mm
电池 Battery:	DC 28V 5.0Ah
净重/毛重 Net weight/Gross weight:	19.79/32.5kg
机器尺寸 Machine dimensions:	550x370x130mm
外包尺寸 Outsourcing size:	665x425x250mm



SP301-E 电动液压开缝器

技术参数 / TECHNICAL DATA

额定压力 Rated pressure:	720bar
最小契入距离 Minimum wedge distance:	≥6mm
最大开启距离 Maximum opening distance:	≤50mm
电池 Battery:	DC 28V 5.0Ah
净重/毛重 Net weight/Gross weight:	20.0kg / 34.5kg
机器尺寸 Machine dimensions:	810X270X150mm
外包尺寸 Outsourcing size:	1150x440x380mm



S250-E 电动液压混凝土破碎器

技术参数 / TECHNICAL DATA

额定压力 Rated pressure:	720bar
牵引距离 Towing distance:	310mm
剪切范围 Cutting range:	Φ28mmQ235圆钢
扩张距离 Spreading distance:	350mm
扩张力 Expansion tension:	130KN
电池 Battery:	DC 28V 5.0Ah
净重/毛重 Net weight/Gross weight:	16.0/30.5kg
机器尺寸 Machine dimensions:	1075x220x180mm
外包尺寸 Outsourcing size:	1150x440x380mm



S225-E 电动液压混凝土破碎器

技术参数 / TECHNICAL DATA

额定压力 Rated pressure:	720bar
破损力 Breakage force:	70KN
破锁开口距离 Opening distance of lock breaking:	300mm
剪切开口距离 Cutting opening distance:	100mm
剪切范围 Cutting range:	Φ30mmQ235圆钢
电池 Battery:	DC 28V 5.0Ah
净重/毛重 Net weight/Gross weight:	20.0/34.5kg
机器尺寸 Machine dimensions:	810x425x325mm
外包尺寸 Outsourcing size:	1100x315x380mm



S325-E 电动液压混凝土破碎器

技术参数 / TECHNICAL DATA

额定压力 Rated pressure:	720bar
破损力 Breakage force:	80KN
破锁开口距离 Opening distance of lock breaking:	320mm
剪切开口距离 Cutting opening distance:	110mm
剪切范围 Cutting range:	Φ30mmQ235圆钢
电池 Battery:	DC 28V 5.0Ah
净重/毛重 Net weight/Gross weight:	23.0/37.5kg
机器尺寸 Machine dimensions:	810x425x325mm
外包尺寸 Outsourcing size:	1100x315x380mm



DAC2500T1 便携式移动电源

技术参数 / TECHNICAL DATA

额定功率 Rated power:	6000W
电池容量 Battery capacity:	2160WH
充电时长 Charging duration:	3-5h
工作时长 Working hours:	7-8h
持续输出功率 Continuous output power:	≤2200W
电池循环寿命 Battery cycle life:	2500+次
满电工作电压 Full power operating voltage:	26.5-27V
电池类别 Battery category:	汽车级动力磷酸铁锂防爆电芯
备注 Remarks:	可根据需求定制功率、续航、太阳能充电、交直流输出接口配置



智能显示屏，多插口可用

S257E 电动液压剪扩钳



技术参数 / TECHNICAL DATA

额定压力 Rated pressure:	720bar
电压 Voltage:	220V/50Hz
电机功率 Motor power:	1.8KW
牵引力 Tractive force:	57KN
牵引距离 Towing distance:	228mm
最大剪切 Maximum shear:	387KN
剪切范围 Cutting range:	Φ32mm圆钢/16mm钢板
最大扩张 Maximum expansion:	58.07KN
扩张距离 Spreading distance:	360mm
净重 Net weight:	20.64kg
机器尺寸 Machine dimensions:	1000x260x230mm

S212C 电动液压剪切器



技术参数 / TECHNICAL DATA

电压 Voltage:	220V/50Hz
电机功率 Motor power:	1.8KW
开口距离 Opening distance:	113mm
切断速度 Cut off speed:	10-15s
剪切力 Shear force:	≤323KN
剪切范围 Cutting range:	Φ28mmQ235圆钢
换向方式 Reversing mode:	手动换向
净重 Net weight:	21.0kg
液压油 Hydraulic oil:	10# 航天液压油
机器尺寸 Machine dimensions:	895x215x173mm

RC-32L 电动液压金属切断器

技术参数 / TECHNICAL DATA

电压 Voltage:	220/230V
功率 power:	1800W
频率 Frequency:	50-60Hz
切断速度 Cut off speed:	3-5s
切断范围 Cut off range:	8-32mm
净重/毛重 Net weight/Gross weight:	16.5/21.0kg
外包尺寸 Outsourcing size:	620x370x200mm
机器尺寸 Machine dimensions:	535x237x132mm



轻型液压破拆救援工具组 LIGHT HYDRAULIC DEMOLITION AND RESCUE TOOL SET

EMEADS[®]
ZHEJIANG EMEADS TOOLS CO., LTD

BE-SC-240S 轻型剪扩钳



技术参数 / TECHNICAL DATA

额定压力 Rated pressure:	630bar
扩张力 expansion tension:	18-33KN
扩张距离 Spreading distance:	255mm
剪切力 shear force:	Φ24mm圆钢/8mm钢板
净重/毛重 Net weight/Gross weight:	9.0/11.0kg
机器尺寸 Machine dimensions:	660x160x140mm
外包尺寸 Outsourcing size:	680x250x150mm
特征 Features:	剪切扩张双重功能, 重量更轻体积更小, 单人背负即可轻松到达救援现场

BE-HE-500S 轻型扩张器



技术参数 / TECHNICAL DATA

额定压力 Rated pressure:	630bar
扩张力 expansion tension:	35-50KN
扩张距离 Spreading distance:	515mm
净重/毛重 Net weight/Gross weight:	11.0/13.5kg
机器尺寸 Machine dimensions:	600x160x140mm
外包尺寸 Outsourcing size:	600x200x190mm
特征 Features:	头部扁平设计, 可嵌入极小的缝隙, 单人背负即可轻松到达救援现场

BE-SC-110S 轻型剪切器



技术参数 / TECHNICAL DATA

额定压力 Rated pressure:	630bar
剪切范围 Cutting range:	Φ25mm圆钢/8mm钢板
最大剪切力 Maximum shear force:	420KN
开口距离 Opening distance:	110mm
净重/毛重 Net weight/Gross weight:	9.0/10.5kg
机器尺寸 Machine dimensions:	600x160x140mm
外包尺寸 Outsourcing size:	600x200x190mm
特征 Features:	巧妙利用弧形刀片的回拉作用, 使其能克服各种结构的车辆

BE-HR-100S 轻型撑顶器



技术参数 / TECHNICAL DATA

额定压力 Rated pressure:	630bar
撑顶力 Jacking force:	100KN
活塞行程 Piston stroke:	200mm
撑顶长度范围 Support length range:	350-550mm
净重/毛重 Net weight/Gross weight:	8.5/9.8kg
机器尺寸 Machine dimensions:	480x100x290mm
外包尺寸 Outsourcing size:	510x140x310mm
特征 Features:	活塞杆头和顶杆底座的防滑爪型结构使顶杆在倾斜或平滑的表面都能安全稳固

BE-MP-63/0.5 轻型机动泵

技术参数 / TECHNICAL DATA

额定压力 Rated pressure:	630bar
发动机功率 Engine power:	1.3KW
低/高压输出 Low/high voltage output:	2.45-0.3L/min
工作转速 Operating speed:	4850±200rpm
油箱容量 Fuel tank capacity:	1.8L
净重/毛重 Net weight/Gross weight:	≤14/15.0kg
机器尺寸 Machine dimensions:	310x280x330mm
外包尺寸 Outsourcing size:	360x300x390mm
特征 Features:	单接口设计, 可带压操作



SC257 液压剪扩钳

技术参数 / TECHNICAL DATA

额定压力 Rated pressure:	630bar
牵引力 Tractive force:	52KN
牵引距离 Towing distance:	228mm
最大剪切力 Maximum shear force:	340KN
剪切范围 Cutting range:	Φ30mm圆钢/16mm铁板
最大扩张力 Maximum expansion tension:	33.88-43.86KN
扩张距离 Spreading distance:	≥370mm
净重/毛重 Net weight/Gross weight:	15.6/22kg
机器尺寸 Machine dimensions:	810x230x160mm
外包尺寸 Outsourcing size:	1225x300x210mm
附件 Enclosure:	木箱、油管
特征 Features:	剪切扩张双重功能，用于消防救援车辆/废品破拆



SP210 液压扩张器

技术参数 / TECHNICAL DATA

额定压力 Rated pressure:	630bar
最大牵引力 Maximum Tractive force:	62KN
最大牵引距离 Maximum Towing distance:	465mm
最大扩张力 Maximum expansion tension:	53.16-71.66KN
最大扩张距离 Maximum Spreading distance:	604mm
净重/毛重 Net weight/Gross weight:	19.7/27.1kg
机器尺寸 Machine dimensions:	710x230x160mm
外包尺寸 Outsourcing size:	1225x300x210mm
附件 Enclosure:	木箱、油管
特征 Features:	头部为扁平设计，可嵌入极小的缝隙星状换向阀，简单又方便



S211 液压剪切器

技术参数 / TECHNICAL DATA

额定压力 Rated pressure:	630bar
开口距离 Opening distance:	128mm
最大剪切力 Maximum shear force:	420KN
剪切范围 Cutting range:	Φ32mmQ235圆钢
净重/毛重 Net weight/Gross weight:	14.42/20.8kg
机器尺寸 Machine dimensions:	710x230x160mm
外包尺寸 Outsourcing size:	1225x300x210mm
附件 Enclosure:	木箱、油管
特征 Features:	利用弧形刀头的回拉作用，使其能克服各种结构的车辆



R410 液压撑顶器

技术参数 / TECHNICAL DATA

额定压力 Rated pressure:	630bar
活塞行程 Piston stroke:	400mm
撑顶力 Jacking force:	123.41KN
撑顶长度范围 Support length range:	940mm
净重/毛重 Net weight/Gross weight:	12.14/15.3kg
机器尺寸 Machine dimensions:	550x110x200mm
外包尺寸 Outsourcing size:	650x270x170mm
附件 Enclosure:	木箱、油管
特征 Features:	活塞杆头和顶杆底座的防滑爪型结构使顶杆在倾斜或平滑的表面都能安全稳固



BE-BS63 液压手动泵

技术参数 / TECHNICAL DATA

额定压力 Rated pressure:	630bar
油箱容量 Fuel tank capacity:	1.3L
低压输出压力 Low pressure output pressure:	50-100bar
高压流量 High pressure flow:	1.5ml/次
低压流量 Low pressure flow:	12ml/次
最大手柄力 Maximum handle force:	350N
净重/毛重 Net weight/Gross weight:	7.0/14.5kg
机器尺寸 Machine dimensions:	550x150x190mm
外包尺寸 Outsourcing size:	355x290x390mm
证书 Certificate:	CE RoHS
附件 Enclosure:	木箱、油管
特征 Features:	简单操作，轻松省力，无电操作



BJQ-63/0.66A 液动机泵

技术参数 / TECHNICAL DATA

额定压力 Rated pressure:	630barx2
工作转速 Operating speed:	3200±200rpm
油箱容量 Fuel tank capacity:	3L
高/低压流量 High/Low pressure flow:	2*0.5L/min;2*1.8L/min
发动机功率 Engine power:	2.2KW
发动机速度 Engine speed:	2600r/min
净重/毛重 Net weight/Gross weight:	23.94/37.0kg
机器尺寸 Machine dimensions:	460x330x430mm
外包尺寸 Outsourcing size:	460x430x490mm
附件 Enclosure:	木箱、油管
特征 Features:	双输出结构，可连接2款设备同时使用，并且四冲程发动机性能更稳定



SC357B 液压剪扩钳

技术参数 / TECHNICAL DATA

额定压力 Rated pressure:	700bar
牵引力 Tractive force:	57KN
牵引距离 Towing distance:	228mm
最大剪切力 Maximum shear force:	387KN
剪切范围 Cutting range:	Φ33mm圆钢/16mm铁板
最大扩张力 Maximum expansion tension:	43.59-47.08KN
扩张距离 Spreading distance:	375mm
净重/毛重 Net weight/Gross weight:	15.28/23kg
机器尺寸 Machine dimensions:	770x190x180mm
外包尺寸 Outsourcing size:	1250x300x205mm
附件 Enclosure:	木箱、说明书、保修卡、合格证
特征 Features:	使用便携, 无需重新组合就能稳定切割并扩张, 可使用牵拉链条进行拖拽操作



SP310B 液压扩张器

技术参数 / TECHNICAL DATA

额定压力 Rated pressure:	700bar
最大牵引力 Maximum Tractive force:	41KN
最大牵引距离 Maximum Towing distance:	573mm
最大扩张力 Maximum expansion tension:	51.48-68.25KN
最大扩张距离 Maximum Spreading distance:	700mm
净重/毛重 Net weight/Gross weight:	20.19/29.4kg
机器尺寸 Machine dimensions:	800x340x220mm
外包尺寸 Outsourcing size:	1175x385x230mm
附件 Enclosure:	木箱、说明书、保修卡、合格证
特征 Features:	无需更换扩张头即可进行扩张、撕裂和牵拉操作, 独特的人体工学设计



S311B 液压剪切器

技术参数 / TECHNICAL DATA

额定压力 Rated pressure:	700bar
最大剪切力 Maximum shear force:	642KN
剪切范围 Cutting range:	Φ33mmQ235圆钢
开口距离 Opening distance:	150mm
净重/毛重 Net weight/Gross weight:	13.88/22.4kg
机器尺寸 Machine dimensions:	770x190x180mm
外包尺寸 Outsourcing size:	1150x300x205mm
附件 Enclosure:	木箱、说明书、保修卡、合格证
特征 Features:	采用“流线型”技术设计, 适用于剪切车辆部件, 性能远超过去同型号产品



R412B 液压撑顶器

技术参数 / TECHNICAL DATA

额定压力 Rated pressure:	700bar
撑顶力 Jacking force:	142.38KN
撑顶行程 Jacking stroke:	498mm
撑顶长度范围 Support length range:	642-1140mm
净重/毛重 Net weight/Gross weight:	13.69/19.2kg
机器尺寸 Machine dimensions:	660x110x200mm
外包尺寸 Outsourcing size:	745x275x170mm
附件 Enclosure:	木箱、说明书、保修卡、合格证
特征 Features:	BELTON特有的星状手控阀可在任何角度和位置进行方便安全的操作



BS-72 液压手动泵

技术参数 / TECHNICAL DATA

额定压力 Rated pressure:	700bar
油箱容量 Fuel tank capacity:	1.3L
低压输出压力 Low pressure output pressure:	50-100bar
高压流量 High pressure flow:	1.5ml/次
低压流量 Low pressure flow:	12ml/次
最大手柄力 Maximum handle force:	350N
净重/毛重 Net weight/Gross weight:	7.0/14.5kg
机器尺寸 Machine dimensions:	550x150x190mm
外包尺寸 Outsourcing size:	355x290x390mm
证书 Certificate:	CE RoHS
附件 Enclosure:	木箱、说明书、保修卡、合格证
特征 Features:	简单操作，轻松省力，无电操作



P630SGB 液动机动泵

技术参数 / TECHNICAL DATA

额定压力 Rated pressure:	700bar
工作转速 Operating speed:	3400±150rpm
油箱容量 Fuel tank capacity:	3L
高/低压流量 High/Low pressure flow:	2*0.7L/min;2*3.0L/min
发动机功率 Engine power:	2.2KW
发动机速度 Engine speed:	3600r/min
净重/毛重 Net weight/Gross weight:	25.2/41.7kg
机器尺寸 Machine dimensions:	310x280x330mm
外包尺寸 Outsourcing size:	550x385x570mm
附件 Enclosure:	木箱、说明书、保修卡、合格证
特征 Features:	可连接2件工具同时使用；带涡轮增压双倍流量功能



GYCQ-315 混凝土破碎器



技术参数 / TECHNICAL DATA

额定压力 Rated pressure:	630bar
最大剪切力 Maximum Shear force:	80KN
开口距离 Opening distance:	315mm
剪切范围 Cutting range:	Φ32mmQ235圆钢
净重 Net weight:	24.2kg
机器尺寸 Machine dimensions:	795x420x325mm
附件 Enclosure:	液压油、油管

GYJQ-250 电动液压鹰嘴剪



技术参数 / TECHNICAL DATA

额定压力 Rated pressure:	700bar
最大剪切 Maximum Shear :	Φ28mmQ235圆钢
开口距离 Opening distance:	305mm
最大扩张力 Maximum expansion tension:	130KN
净重 Net weight:	15kg
机器尺寸 Machine dimensions:	1075x220x180mm
附件 Enclosure:	液压油、油管

重型液压破拆救援工具组 HEAVY HYDRAULIC DEMOLITION AND RESCUE TOOL SET

EMEADS[®]
ZHEJIANG EMEADS TOOLS CO., LTD

SC557B 液压剪扩钳

技术参数 / TECHNICAL DATA

额定压力 Rated pressure:	700bar
牵引力 Tractive force:	67KN
牵引距离 Towing distance:	281mm
最大剪切力 Maximum shear force:	810KN
剪切范围 Cutting range:	Φ40mm圆钢
最大扩张力 Maximum expansion tension:	40.52-52.41KN
扩张距离 Spreading distance:	410mm
净重/毛重 Net weight/Gross weight:	20.43/25.5kg
机器尺寸 Machine dimensions:	850x295x160mm
外包尺寸 Outsourcing size:	1240x300x210mm
附件 Enclosure:	木箱、说明书、保修卡、合格证
特征 Features:	使用便携, 无需重新组合就能稳定切割并扩张, 可使用牵拉链条进行拖拽操作



消防救援系列

FIRE RESCUE SERIES

SP510B 液压扩张器

技术参数 / TECHNICAL DATA

额定压力 Rated pressure:	700bar
最大牵引力 Maximum Tractive force:	44.57-57.65KN
最大牵引距离 Maximum Towing distance:	665mm
最大扩张力 Maximum expansion tension:	230KN
最大扩张距离 Maximum Spreading distance:	820mm
净重/毛重 Net weight/Gross weight:	21.11/28.5kg
机器尺寸 Machine dimensions:	840x340x220mm
外包尺寸 Outsourcing size:	1175x385x230mm
附件 Enclosure:	木箱、说明书、保修卡、合格证
特征 Features:	无需更换扩张头即可进行扩张、撕裂和牵拉操作, 独特的人体工学设计



S511B 液压剪切器

技术参数 / TECHNICAL DATA

额定压力 Rated pressure:	700bar
最大剪切力 Maximum shear force:	1194KN
剪切范围 Cutting range:	Φ40mmQ235圆钢
开口距离 Opening distance:	165mm
净重/毛重 Net weight/Gross weight:	18.88/25.5kg
机器尺寸 Machine dimensions:	750x230x160mm
外包尺寸 Outsourcing size:	1145x300x210mm
附件 Enclosure:	木箱、说明书、保修卡、合格证
特征 Features:	采用“流线型”技术设计, 适用于剪切车辆部件, 性能远超过去同型号产品



R422B 液压撑顶器

技术参数 / TECHNICAL DATA

额定压力 Rated pressure:	700bar
活塞行程 Piston stroke:	710mm
I级行程/撑顶力 1st stage stroke/jacking force:	268.55KN/370mm
II级行程/撑顶力 2st stage stroke/jacking force:	136.97KN/340mm
撑顶长度范围 Support length range:	1257mm
净重/毛重 Net weight/Gross weight:	18.8/22.5kg
机器尺寸 Machine dimensions:	560x120x200mm
外包尺寸 Outsourcing size:	655x275x180mm
附件 Enclosure:	木箱、说明书、保修卡、合格证
特征 Features:	BELTON特有的星状手控阀可在任何角度和位置进行方便安全的操作



BS-72 液压手动泵

技术参数 / TECHNICAL DATA

额定压力 Rated pressure:	700bar
油箱容量 Fuel tank capacity:	1.3L
低压输出压力 Low pressure output pressure:	50-100bar
高压流量 High pressure flow:	1.5ml/次
低压流量 Low pressure flow:	12ml/次
最大手柄力 Maximum handle force:	350N
净重/毛重 Net weight/Gross weight:	7.0/14.5kg
机器尺寸 Machine dimensions:	550x150x190mm
外包尺寸 Outsourcing size:	355x290x390mm
证书 Certificate:	CE RoHS
附件 Enclosure:	木箱、说明书、保修卡、合格证
特征 Features:	简单操作，轻松省力，无电操作



P630SGB 液动机泵

技术参数 / TECHNICAL DATA

额定压力 Rated pressure:	700bar
工作转速 Operating speed:	3400±150rpm
油箱容量 Fuel tank capacity:	3L
高/低压流量 High/Low pressure flow:	2*0.7L/min; 2*3.0L/min
发动机功率 Engine power:	2.2KW
发动机速度 Engine speed:	3600r/min
净重/毛重 Net weight/Gross weight:	25.2/41.7kg
机器尺寸 Machine dimensions:	310x280x330mm
外包尺寸 Outsourcing size:	550x385x570mm
附件 Enclosure:	木箱、说明书、保修卡、合格证
特征 Features:	可连接2件工具同时使用；带涡轮增压双倍流量功能



升级版两栖套件 UPGRADED AMPHIBIOUS KIT

EMEADS[®]
ZHEJIANG EMEADS TOOLS CO., LTD

BJQ-700 水陆两用电动液压泵

技术参数 / TECHNICAL DATA

额定工作压力 Rated working pressure:	≥700Mpa
锂电池容量 Lithium battery flow:	≥5Ah
高压流量 High pressure flow:	≥0.45L/min
低压流量 Low pressure flow:	≥2.4L/min
重量 weight:	≤25.0kg
特征 Features:	具电量显示/渗水警示功能, 单接口设计可带压插拔。



SC357B 液压剪扩钳

技术参数 / TECHNICAL DATA

额定压力 Rated pressure:	700bar
牵引力 Tractive force:	57KN
牵引距离 Towing distance:	228mm
最大剪切力 Maximum shear force:	387KN
剪切范围 Cutting range:	Φ33mm圆钢/16mm铁板
最大扩张力 Maximum expansion tension:	43.59-47.08KN
扩张距离 Spreading distance:	375mm
净重/毛重 Net weight/Gross weight:	15.28/23kg
机器尺寸 Machine dimensions:	770x190x180mm
外包尺寸 Outsourcing size:	1250x300x205mm
附件 Enclosure:	木箱、说明书、保修卡、合格证
特征 Features:	使用便携, 无需重新组合就能稳定切割并扩张, 可使用牵拉链条进行拖拽操作



SP310B 液压扩张器

技术参数 / TECHNICAL DATA

额定压力 Rated pressure:	700bar
最大牵引力 Maximum Tractive force:	41KN
最大牵引距离 Maximum Towing distance:	573mm
最大扩张力 Maximum expansion tension:	51.48-68.25KN
最大扩张距离 Maximum Spreading distance:	700mm
净重/毛重 Net weight/Gross weight:	20.19/29.4kg
机器尺寸 Machine dimensions:	800x340x220mm
外包尺寸 Outsourcing size:	1175x385x230mm
附件 Enclosure:	木箱、说明书、保修卡、合格证
特征 Features:	无需更换扩张头即可进行扩张、撕裂和牵拉操作, 独特的人体工学设计



S311B 液压剪切器

技术参数 / TECHNICAL DATA

额定压力 Rated pressure:	700bar
最大剪切力 Maximum shear force:	642KN
剪切范围 Cutting range:	Φ33mmQ235圆钢
开口距离 Opening distance:	150mm
净重/毛重 Net weight/Gross weight:	13.88/22.4kg
机器尺寸 Machine dimensions:	770x190x180mm
外包尺寸 Outsourcing size:	1150x300x205mm
附件 Enclosure:	木箱、说明书、保修卡、合格证
特征 Features:	采用“流线型”技术设计, 适用于剪切车辆部件, 性能远超过去同型号产品



BE-WP13-30 液压动力站

技术参数 / TECHNICAL DATA

发动机 Engine:	百力通13.5HP
外形尺寸 Overall dimensions:	870x580x600mm
重量 weight:	75kg
液压流量 Hydraulic flow:	20-30lpm
最大油压 Maximum oil pressure:	155bar
液压油箱容积 Hydraulic oil tank volume:	13L
燃油箱容积 Fuel tank volume:	6.5L
电启动 Electric starting:	可选
声压等级 Sound pressure level:	88DB
附件 Enclosure:	护框、移动轮、工作计时表、液压油位计
特征 Features:	是一个多用途液压动力站，结构紧凑，重量轻，不锈钢框架，抗震性好



BE-WP18-40 液压动力站

技术参数 / TECHNICAL DATA

发动机 Engine:	百力通18HP
外形尺寸 Overall dimensions:	900x580x750mm
重量 weight:	118kg
液压流量 Hydraulic flow:	30-40lpm
最大油压 Maximum oil pressure:	155bar
液压油箱容积 Hydraulic oil tank volume:	16L
燃油箱容积 Fuel tank volume:	22L
电启动 Electric starting:	有
声压等级 Sound pressure level:	95DB
附件 Enclosure:	护框、移动轮、工作计时表、液压油位计
特征 Features:	是一个多用途液压动力站，风扇降温的大容量液压油散热器



BE-BW18S 液压破碎镐

技术参数 / TECHNICAL DATA

工作压力 Working pressure:	90-140bar
外形尺寸 Overall dimensions:	650x450mm
重量 weight:	18kg
液压油流量 Hydraulic oil flow:	26-34lpm
冲击频率 Impact frequency:	1500-2000bpm
镐钎 Pick drill:	1*4-1/4in.Hex
手柄形状 Handle shape:	V型减震手柄
附件 Enclosure:	钎头
特征 Features:	破碎力强劲，操作平稳，磨损小，工作寿命长，日常维护简单

