

CUTTER SERIES

EMEADS[®]

ZHEJIANG EMEADS TOOLS CO., LTD



POWERFUL POWER
AND EFFICIENT OPERATION

135C CHARGING TYPE HYDRAULIC CABLE CUTTER

25T EBS-135C



25T EB-135C



25T DES-135C (Brushless drive)



25T DE-135C (Brushless drive)



TECHNICAL DATA	
Cutting force:	200KN
Stroke:	62mm
Cutting times:	40times (Per saturation voltage) (4.0 Standard configuration)
Cutting range:	Φ130mm _{max} Armoured and Cu/Al cable
Voltage/capacity:	18V/4.0Ah/9.0Ah
Gross weight/Net weight:	24kg/11kg
Charging time:	2 hours
Package:	Plastic box
ACCESSORIES	
Battery:	2pcs
Charger:	1pc



120C CHARGING TYPE HYDRAULIC CABLE CUTTER

25T EBS-120C



25T EB-120C



25T DES-120C (Brushless drive)



25T DE-120C (Brushless drive)



TECHNICAL DATA

Cutting force:	200KN
Stroke:	62mm
Cutting times:	50times (Per saturation voltage)
Cutting range:	Φ110mm _{max} Armoured and Cu/Al cable
Voltage/capacity:	18V/4.0Ah/9.0Ah
Gross weight/Net weight:	23kg/11kg
Charging time:	2 hours
Package:	Plastic box

ACCESSORIES

Battery:	2pcs
Charger:	1pc



CHARGING TYPE HYDRAULIC CABLE CUTTER

120C CHARGING TYPE HYDRAULIC CABLE CUTTER

15T EBS-120C



15T EB-120C



15T DES-120C (Brushless drive)



15T DE-120C (Brushless drive)



TECHNICAL DATA

Cutting force:	150KN
Stroke:	62mm
Cutting times:	50times (Per saturation voltage)
Cutting range:	Φ100mm _{max} Armoured and Cu/Al cable
Voltage/capacity:	18V/4.0Ah/9.0Ah
Gross weight/Net weight:	19kg/9kg
Charging time:	2 hours
Package:	Plastic box
ACCESSORIES	
Battery:	2pcs
Charger:	1pc



105C CHARGING TYPE HYDRAULIC CABLE CUTTER

25T EBS-105C



25T EB-105C



25T DES-105C (Brushless drive)



25T DE-105C (Brushless drive)



TECHNICAL DATA

Cutting force:	200KN
Stroke:	62mm
Cutting times:	70times (Per saturation voltage)
Cutting range:	Φ100mm _{max} Armoured and Cu/Al cable
Voltage/capacity:	18V/4.0Ah/9.0Ah
Gross weight/Net weight:	23kg/10-12kg
Charging time:	2 hours
Package:	Plastic box
ACCESSORIES	
Battery:	2pcs
Charger:	1pc



CHARGING TYPE HYDRAULIC CABLE CUTTER

105C CHARGING TYPE HYDRAULIC CABLE CUTTER

15T EBS-105C



15T EB-105C



15T DES-105C (Brushless drive)



15T DE-105C (Brushless drive)



TECHNICAL DATA

Cutting force:	150KN
Stroke:	62mm
Cutting times:	70times (Per saturation voltage)
Cutting range:	Φ85mm _{max} Armoured and Cu/Al cable
Voltage/capacity:	18V/4.0Ah/9.0Ah
Gross weight/Net weight:	15g/10-12kg
Charging time:	2 hours
Package:	Plastic box

ACCESSORIES

Battery:	2pcs
Charger:	1pc



105 CHARGING TYPE HYDRAULIC CABLE CUTTER

EBS-105



With continuous function

EB-105



Regular function

DES-105 (Brushless drive)



With continuous function

DE-105 (Brushless drive)



Regular function

TECHNICAL DATA

Cutting force:	120KN
Stroke:	105mm
Cutting times:	130times (Per saturation voltage)
Cutting range:	Φ95mm _{max} Armoured and Cu/Al cable
Voltage/capacity:	18V/4.0Ah/9.0Ah
Net weight:	6.5kg
Charging time:	2 hours
Package:	Plastic box
ACCESSORIES	
Battery:	2pcs
Charger:	1pc



85C CHARGING TYPE HYDRAULIC CABLE CUTTER

EBS-85C



EB-85C



DES-85C (Brushless drive)



DE-85C (Brushless drive)



TECHNICAL DATA

Cutting force:	120KN
Stroke:	42mm
Cutting times:	70times (Per saturation voltage)
Cutting range:	Φ70mm _{max} Armoured and Cu/Al cable
Voltage/capacity:	18V/4.0Ah/9.0Ah
Net weight:	6.0kg
Charging time:	2 hours
Package:	Plastic box

ACCESSORIES

Battery:	2pcs
Charger:	1pc



85 CHARGING TYPE HYDRAULIC CABLE CUTTER

EBS-85



With continuous function

EB-85



Regular function

DES-85 (Brushless drive)



With continuous function

DE-85 (Brushless drive)



Regular function

TECHNICAL DATA

Cutting force:	60KN
Stroke:	85mm
Cutting times:	130times (Per saturation voltage)
Cutting range:	Φ70mm _{max} Armoured and Cu/Al cable
Voltage/capacity:	18V/4.0Ah
Net weight:	6.0kg
Charging time:	2 hours
Package:	Plastic box
ACCESSORIES	
Battery:	2pcs
Charger:	1pc



CHARGING TYPE HYDRAULIC CABLE CUTTER

55 CHARGING TYPE HYDRAULIC CABLE CUTTER

EBS-55



EB-55



DES-55 (Brushless drive)



DE-55 (Brushless drive)



TECHNICAL DATA

Cutting force:	120KN
Stroke:	50mm
Cutting times:	70times (Per saturation voltage)
Cutting range:	Φ50mm _{max} Armoured and Cu/Al cable/ACSR stranded wire
Voltage/capacity:	18V/4.0Ah
Net weight:	6.0kg
Charging time:	2 hours
Package:	Plastic box
ACCESSORIES	
Battery:	2pcs
Charger:	1pc



40 CHARGING TYPE HYDRAULIC CABLE CUTTER

EBS-40



With continuous function

EB-40



Regular function

DES-40 (Brushless drive)



With continuous function

DE-40 (Brushless drive)



Regular function

TECHNICAL DATA

Cutting force:	60KN/120KN (120KN optional tong head)
Stroke:	40mm
Cutting times:	130times (Per saturation voltage)
Cutting range:	Φ35mm _{max} ACSR stranded wire
Voltage/capacity:	18V/4.0Ah
Net weight:	6.0kg
Charging time:	2 hours
Package:	Plastic box
ACCESSORIES	
Battery:	2pcs
Charger:	1pc



CHARGING TYPE HYDRAULIC CABLE CUTTER

MINI CHARGING TYPE HYDRAULIC CABLE CUTTER

GE-85C

TECHNICAL DATA	GE-85C
Cutting force:	120KN
Stroke:	35mm
Cutting times:	130times (Per saturation voltage)
Cutting range:	Φ70mm _{max} Armoured and Cu/Al cable
Voltage/capacity:	18V/4.0Ah
Net weight:	4.0kg
Charging time:	2 hours
Package:	Plastic box
ACCESSORIES	
Battery:	2pcs
Charger:	1pc



GE-65C (Special for ACSR)

TECHNICAL DATA	GE-65C
Cutting force:	120KN
Stroke:	35mm
Cutting times:	130times (Per saturation voltage)
Cutting range:	Φ55mm _{max} ACSR stranded wire
Voltage/capacity:	18V/4.0Ah
Net weight:	4.0kg
Charging time:	2 hours
Package:	Plastic box
ACCESSORIES	
Battery:	2pcs
Charger:	1pc



GES-32C / GES-50C

TECHNICAL DATA	GES-32C	GES-50C
Cutting force:	60KN	60KN
Stroke:	30mm	35mm
Cutting times:	130times (Per saturation voltage)	130times (Per saturation voltage)
Cutting range:	Φ30mm _{max} Armoured and Cu/Al cable/ACSR stranded wire	Φ50mm _{max} Armoured and Cu/Al cable/ACSR stranded wire
Voltage/capacity:	18V/4.0Ah	18V/4.0Ah
Net weight:	4.5kg	5.0kg
Charging time:	2 hours	2 hours
Package:	Plastic box	Plastic box
ACCESSORIES		
Battery:	2pcs	2pcs
Charger:	1pc	1pc



GES-40 / GES-55

TECHNICAL DATA	GES-40	GES-55
Cutting force:	60KN	120KN
Stroke:	40mm	50mm
Cutting times:	130times (Per saturation voltage)	70times (Per saturation voltage)
Cutting range:	Φ35mm _{max} ACSR stranded wire	Φ50mm _{max} Armoured and Cu/Al cable/ACSR stranded wire
Charger voltage:	100-240VAC	100-240VAC
Voltage/capacity:	18V/4.0Ah	18V/4.0Ah
Net weight:	3.0kg	6.0kg
Charging time:	2 hours	2 hours
Package:	Plastic box	Plastic box
ACCESSORIES		
Battery:	2pcs	2pcs
Charger:	1pc	1pc



GES-300C-2 / GE-300C-2

TECHNICAL DATA	GES-300C-2 / GE-300C-2
Cutting force:	60KN
Stroke:	17mm
Cutting times:	130times (Per saturation voltage)
Cutting range:	Φ30mm _{max} Armoured and Cu/Al cable
Crimping range:	4-300mm ²
Charger voltage:	100-240VAC
Voltage/capacity:	18V/4.0Ah
Net weight:	3.0kg
Charging time:	2 hours
Package:	Plastic box
ACCESSORIES	
Battery:	2pcs
Charger:	1pc



GES-300C-1 / GE-300C-1

TECHNICAL DATA	GES-300C-1 / GE-300C-1
Cutting force:	60KN
Stroke:	17mm
Cutting times:	130times (Per saturation voltage)
Cutting range:	Φ30mm _{max} Armoured and Cu/Al cable
Crimping range:	16-300mm ²
Charger voltage:	100-240VAC
Voltage/capacity:	18V/4.0Ah
Net weight:	3.0kg
Charging time:	2 hours
Package:	Plastic box
ACCESSORIES	
Battery:	2pcs
Charger:	1pc



REMOTE CONTROL CHARGING TYPE HYDRAULIC CABLE CUTTER

GES-50CY (Remote control/Bluetooth optional)

TECHNICAL DATA	GES-50CY
Cutting force:	60KN
Stroke:	35mm
Cutting times:	130times (Per saturation voltage)
Cutting range:	Φ50mm _{max} Armoured and Cu/Al cable/ACSR stranded wire
Charger voltage:	100-240VAC
Voltage/capacity:	18V/4.0Ah
Net weight:	5.0kg
Charging time:	2 hours
Package:	Plastic box
ACCESSORIES	
Battery:	2pcs
Charger:	1pc
Remote control	2pcs
Hoop	1set
Insulated rod	4.5/6m optional



4G 
Bluetooth APP
remote control



Remote control



GES-32CY (Remote control/Bluetooth optional)

TECHNICAL DATA	GES-32CY
Cutting force:	60KN
Stroke:	30mm
Cutting times:	130times (Per saturation voltage)
Cutting range:	Φ30mm _{max} Armoured and Cu/Al cable/ACSR stranded wire
Charger voltage:	100-240VAC
Voltage/capacity:	18V/4.0Ah
Net weight:	4.5kg
Charging time:	2 hours
Package:	Plastic box
ACCESSORIES	
Battery:	2pcs
Charger:	1pc
Remote control	2pcs
Hoop	1set
Insulated rod	4.5/6m optional



4G 
Bluetooth APP
remote control



Remote control



REMOTE CONTROL CHARGING TYPE HYDRAULIC CABLE CUTTER

EB-105Y (Remote control/Bluetooth optional)

TECHNICAL DATA	EB-105Y
Cutting force:	120KN
Stroke:	105mm
Cutting times:	130times (Per saturation voltage)
Cutting range:	Φ95mm _{max} Armoured and Cu/Al cable
Voltage/capacity:	18V/4.0Ah
Net weight:	6.5kg
Charging time:	2 hours
Package:	Plastic box
ACCESSORIES	
Battery:	2pcs
Charger:	1pc
Remote control	2pcs
Hoop	1set
Grounding rod conductor	4.5/6m optional



25T EB-120CY (Remote control/Bluetooth optional)

TECHNICAL DATA	25T EB-120CY
Cutting force:	150KN
Stroke:	62mm
Cutting times:	50times (Per saturation voltage)
Cutting range:	Φ100mm _{max} Armoured and Cu/Al cable
Voltage/capacity:	18V/4.0Ah
Gross wight/Net weight:	19kg/9kg
Charging time:	2 hours
Package:	Plastic box
ACCESSORIES	
Battery:	2pcs
Charger:	1pc
Remote control	2pcs
Hoop	1set
Grounding rod conductor	4.5/6m optional

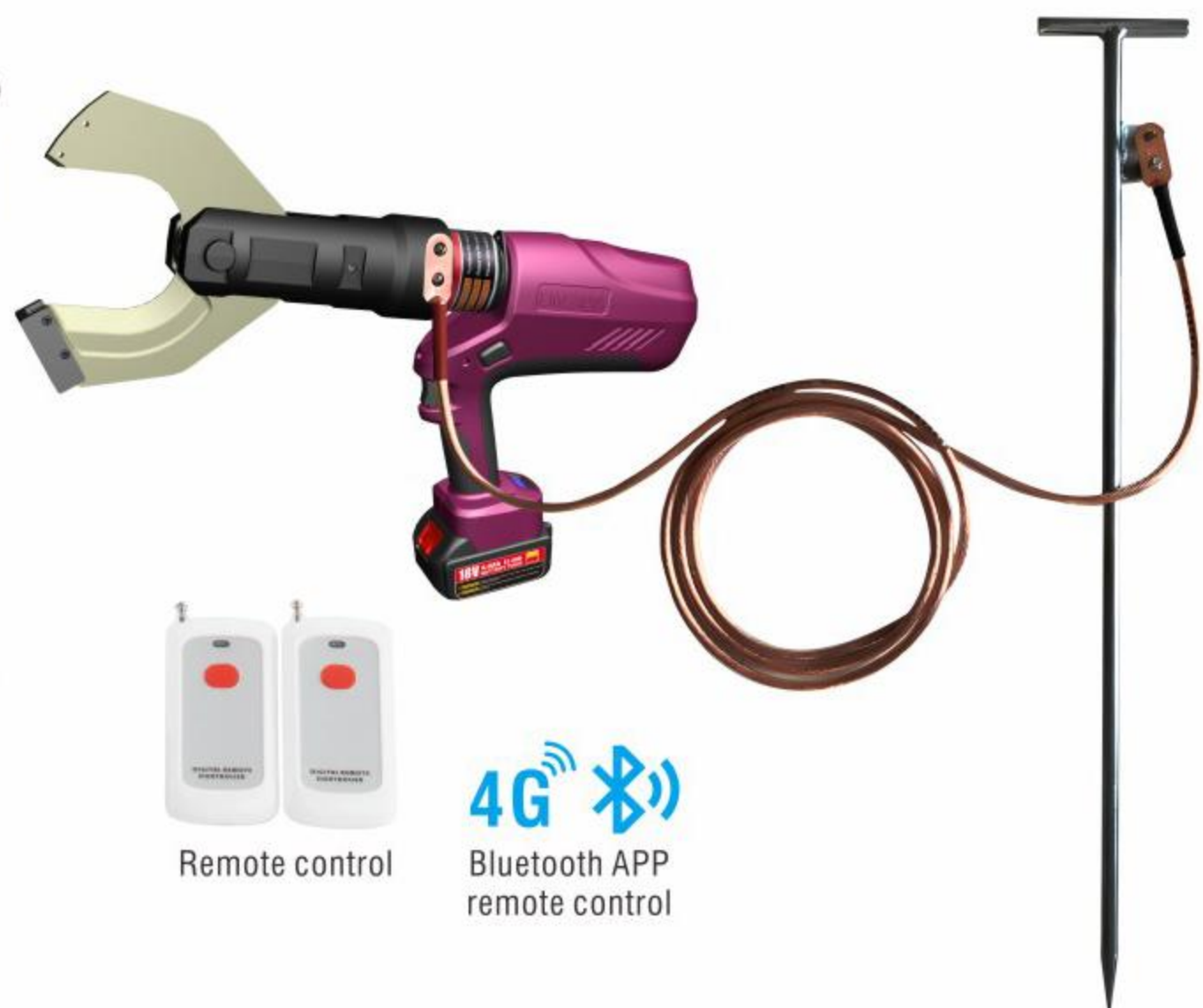

EBS-2000B/135C Backpack electric remote control scissors (Remote control/Bluetooth optional)

TECHNICAL DATA	EBS-2000B/135C
Cutting force:	200KN
Stroke:	62mm
Cutting times:	40times (Per saturation voltage)
Cutting range:	Φ130mm _{max} Armoured and Cu/Al cable
Voltage/capacity:	18V/5.0Ah/9.0Ah optional
Gross weight/Net weight:	24kg/11kg
Charging time:	2 hours
Package:	Plastic box
ACCESSORIES	
Battery:	2pcs
Charger:	1pc
Remote control	2pcs
Hoop	1set
Grounding rod conductor	4.5/6m optional

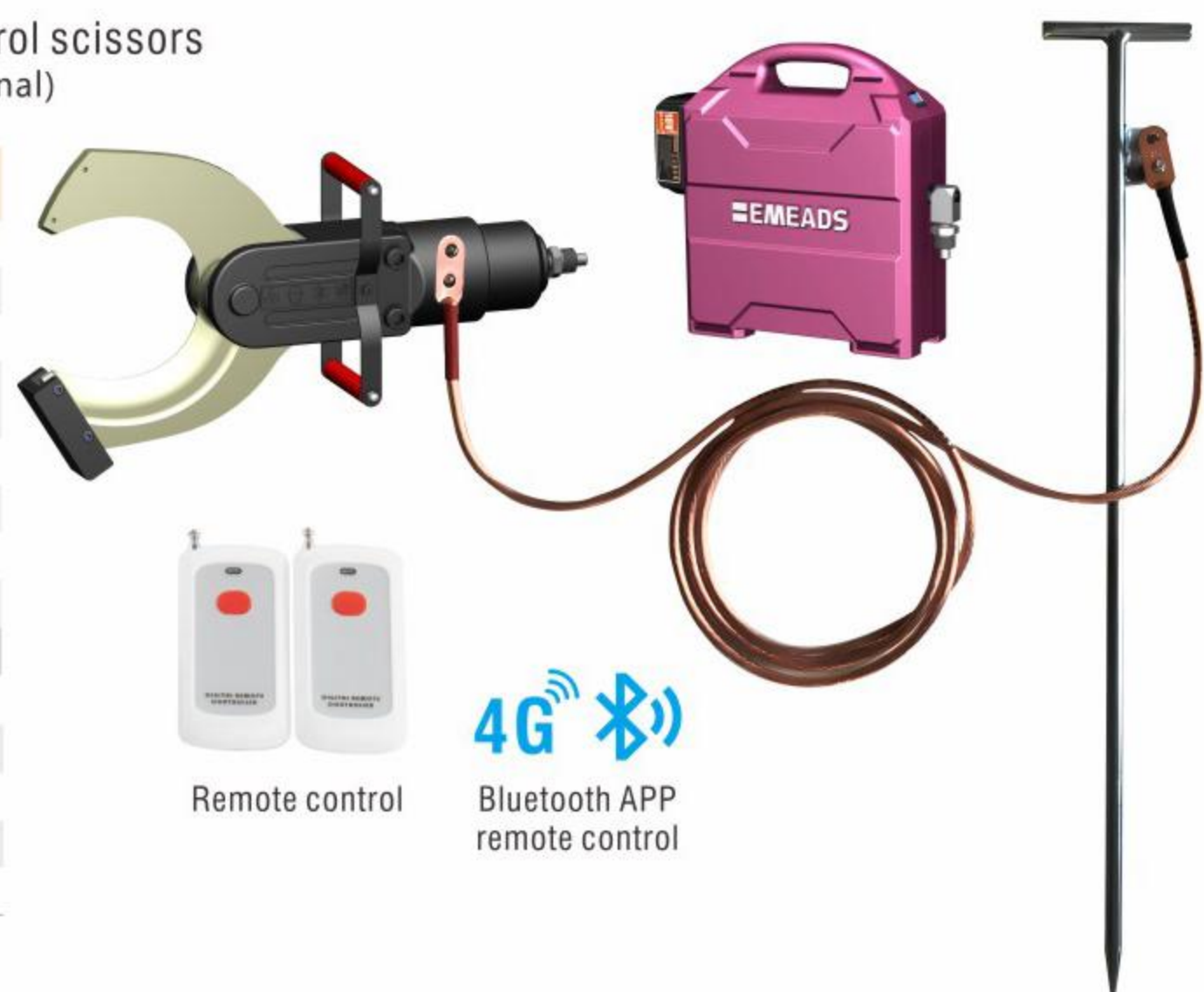

Note: Various split scissors heads are available

RATCHET CHARGING TYPE HYDRAULIC CABLE CUTTER

EMS-50

TECHNICAL DATA	EMS-50
Cutting times:	130times (Per saturation voltage)
Cutting range:	Φ50mmmax Armoured and Cu/Al cable/ACSR stranded wire
Charger voltage:	100-240VAC
Voltage/capacity:	18V/4.0Ah
Net weight:	4.0kg
Charging time:	2 hours
Package:	Plastic box
ACCESSORIES	
Battery:	2pcs
Charger:	1pc



EMS-60

TECHNICAL DATA	EMS-60
Cutting times:	130times (Per saturation voltage)
Cutting range:	Φ60mmmax Armoured and Cu/Al cable
Charger voltage:	100-240VAC
Voltage/capacity:	18V/4.0Ah
Net weight:	4.0kg
Charging time:	2 hours
Package:	Plastic box
ACCESSORIES	
Battery:	2pcs
Charger:	1pc



EMS-85

TECHNICAL DATA	EMS-85
Cutting times:	130times (Per saturation voltage)
Cutting range:	Φ85mmmax Armoured and Cu/Al cable
Charger voltage:	100-240VAC
Voltage/capacity:	18V/4.0Ah
Net weight:	4.0kg
Charging time:	2 hours
Package:	Plastic box
ACCESSORIES	
Battery:	2pcs
Charger:	1pc



135CTG CHARGING TYPE HYDRAULIC IRON PIPE SPECIAL CUTTER

25T DES-135CTG (Brushless drive)

25T EBS-135CTG

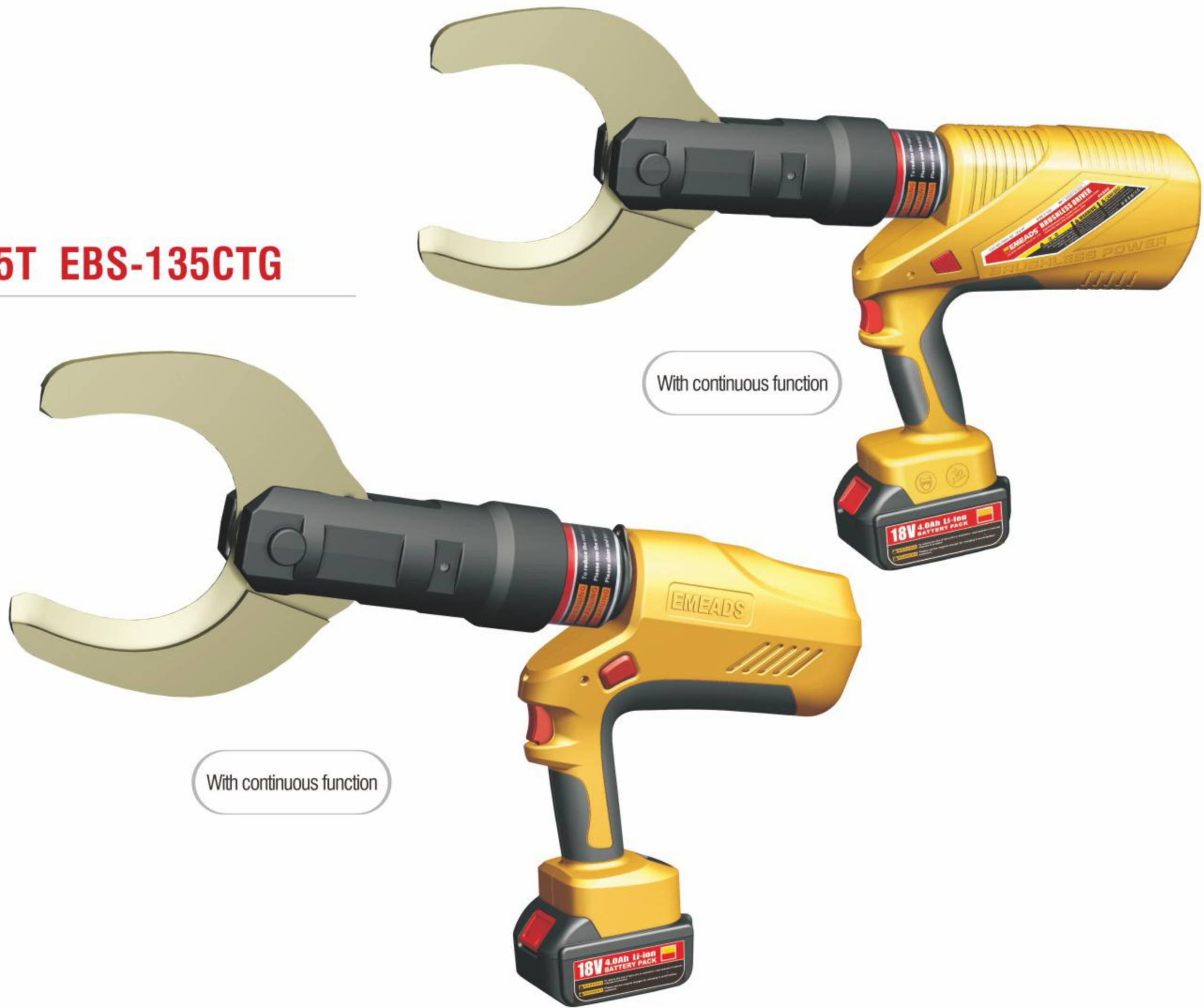

TECHNICAL DATA	
Cutting force:	200KN
Stroke:	62mm
Cutting times:	40times (Per saturation voltage) (4.0 standard configuration)
Cutting range:	84mm Φ 100mm _{max}
Voltage/capacity:	18V/4.0Ah/9.0Ah
Net weight:	11kg
Charging time:	2 hours
Package:	Plastic box
ACCESSORIES	
Battery:	2pcs
Charger:	1pc



CHARGING TYPE HYDRAULIC IRON PIPE SPECIAL CUTTER

120CTG CHARGING TYPE HYDRAULIC IRON PIPE SPECIAL CUTTER

25T DES-120CTG (Brushless drive)



With continuous function

25T EBS-120CTG



With continuous function

TECHNICAL DATA

Cutting force:	200KN
Stroke:	62mm
Cutting times:	50times (Per saturation voltage)
Cutting range:	84mm Φ80mm _{max}
Voltage/capacity:	18V/4.0Ah/9.0Ah
Net weight:	10kg
Charging time:	2 hours
Package:	Plastic box
ACCESSORIES	
Battery:	2pcs
Charger:	1pc



120CTG CHARGING TYPE HYDRAULIC IRON PIPE SPECIAL CUTTER

15T DES-120CTG (Brushless drive)

15T EBS-120CTG

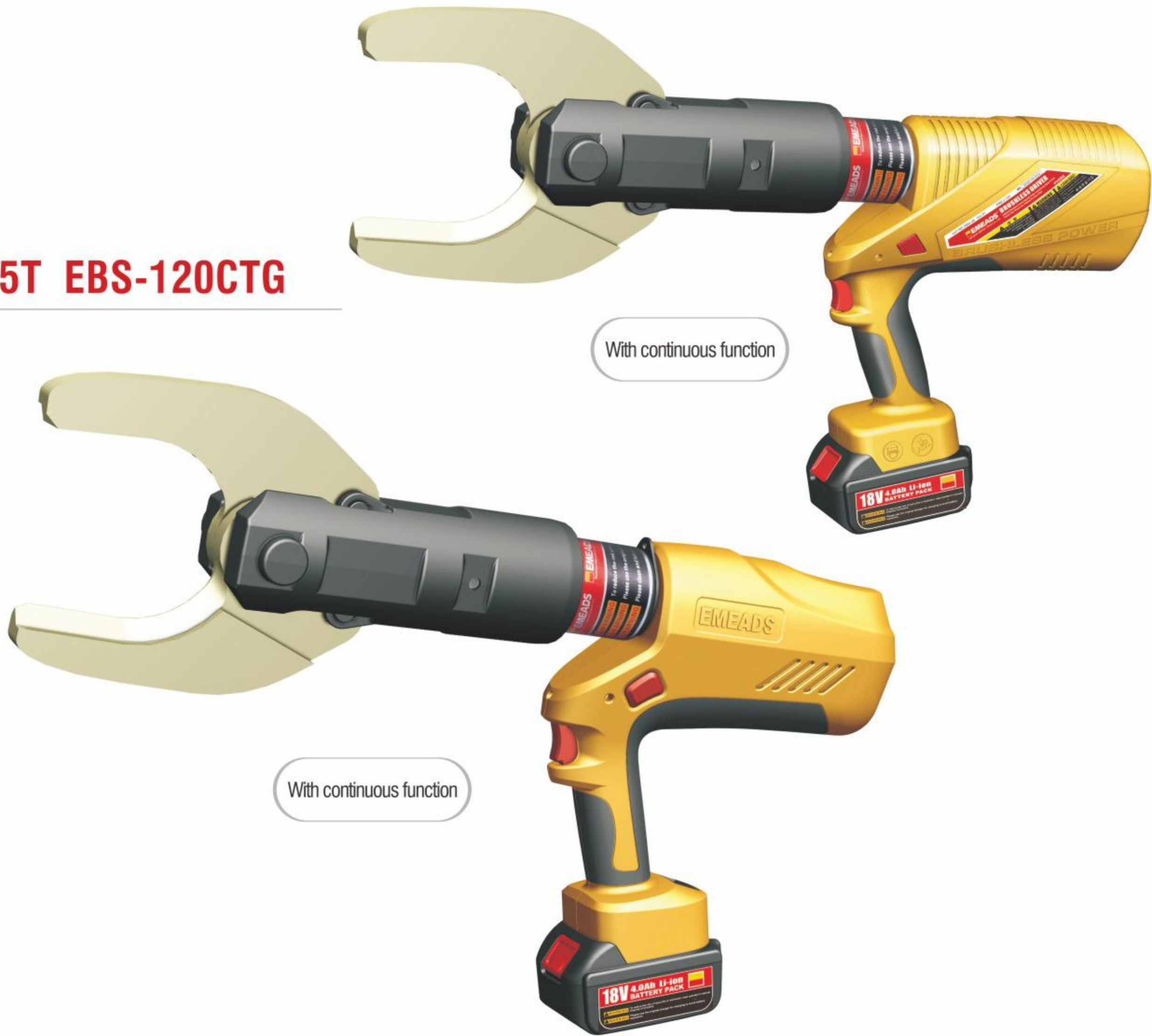

TECHNICAL DATA	
Cutting force:	150KN
Stroke:	62mm
Cutting times:	50times (Per saturation voltage) (4.0 standard configuration)
Cutting range:	δ3mm Φ80mm _{max}
Voltage/capacity:	18V/4.0Ah/9.0Ah
Net weight:	10kg
Charging time:	2 hours
Package:	Plastic box
ACCESSORIES	
Battery:	2pcs
Charger:	1pc



CHARGING TYPE HYDRAULIC IRON PIPE SPECIAL CUTTER

105CTG CHARGING TYPE HYDRAULIC IRON PIPE SPECIAL CUTTER

25T DES-105CTG (Brushless drive)



With continuous function

25T EBS-105CTG

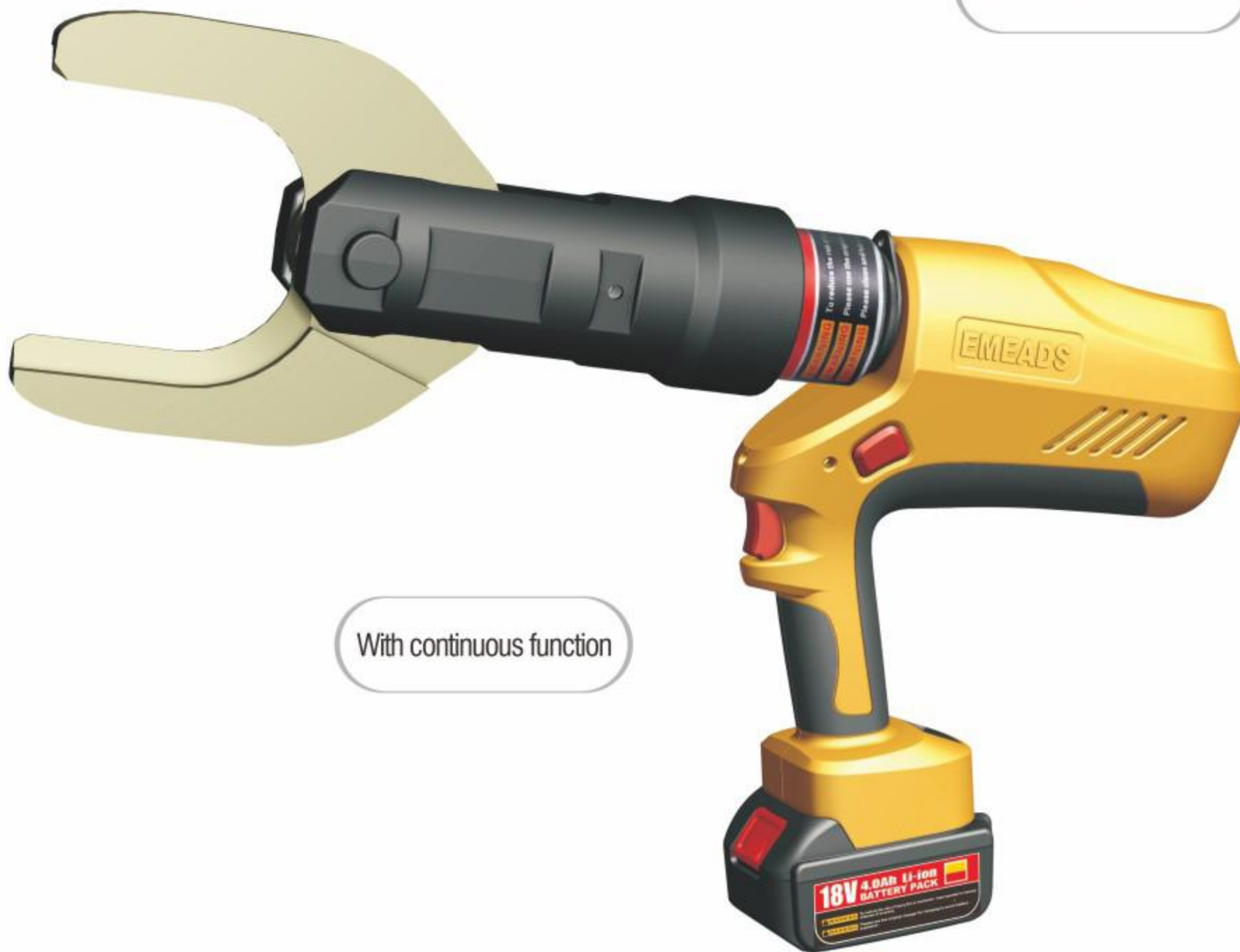

With continuous function

TECHNICAL DATA

Cutting force:	200KN
Stroke:	62mm
Cutting times:	70times (Per saturation voltage) (4.0 standard configuration)
Cutting range:	84mm Φ60mm _{max}
Voltage/capacity:	18V/4.0Ah/9.0Ah
Net weight:	9kg
Charging time:	2 hours
Package:	Plastic box
ACCESSORIES	
Battery:	2pcs
Charger:	1pc



105CTG CHARGING TYPE HYDRAULIC IRON PIPE SPECIAL CUTTER

15T DES-105CTG (Brushless drive)



With continuous function

15T EBS-105CTG



With continuous function

TECHNICAL DATA

Cutting force:	150KN
Stroke:	62mm
Cutting times:	70times (Per saturation voltage) (4.0 standard configuration)
Cutting range:	δ3mm Φ60mm _{max}
Voltage/capacity:	18V/4.0Ah/9.0Ah
Net weight:	9kg
Charging time:	2 hours
Package:	Plastic box

ACCESSORIES

Battery:	2pcs
Charger:	1pc



MANUAL HYDRAULIC CABLE CUTTER

THC-45

With safety system inside

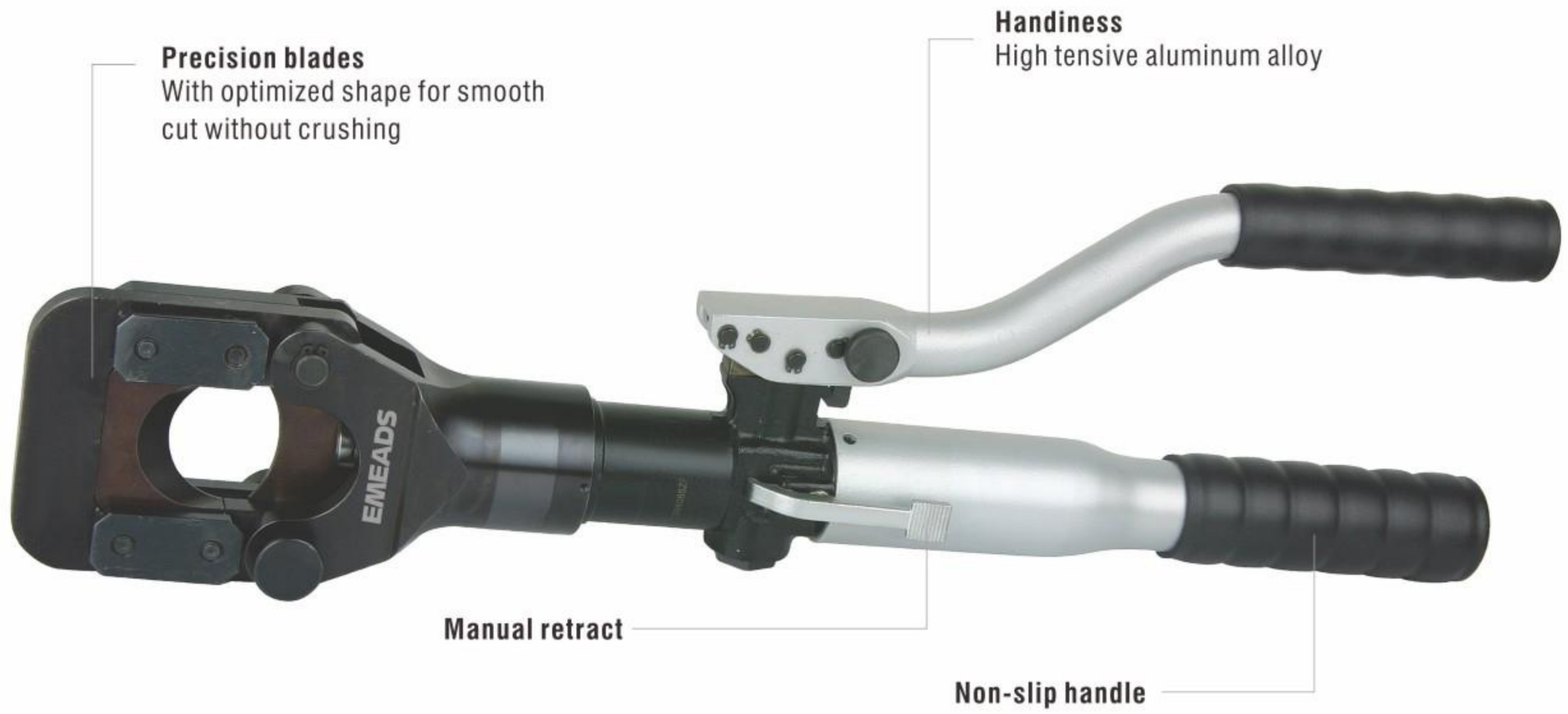

TECHNICAL DATA	THC-45
Cutting force:	60KN
Cutting range:	Φ45mm (Armoured and Cu/Al cable)
Stroke:	50mm
Length:	560mm
Weight:	4.8kg
Package:	steel case
Weight of case:	3.3kg
ACCESSORIES:	
Note: If change knife can cut Φ38mm ACSR/Φ28 steel wire	

- Flip top cutting head rotates 350°.
- Two stage hydraulic to reduce cutting cycle, automatic release pressure when cut is complete.
- Manual release in case of need.

THC-85

With safety system inside

TECHNICAL DATA	THC-85
Cutting force:	60KN
Cutting range:	Φ85mm (Armoured and Cu/Al cable)
Stroke:	86mm
Length:	680mm
Weight:	7.6kg
Package:	steel case
Weight of case:	3.8kg



CPC-50



TECHNICAL DATA	CPC-50
Cutting force:	60KN
Cutting range:	Φ40mm _{max} for telephone cable Φ32mm _{max} for armoured Cu/Al cable
Stroke:	48mm
Length:	580mm
Weight:	5.2kg
Package:	steel case
Weight of case:	3.25kg

CPC-85



TECHNICAL DATA	CPC-85
Cutting force:	60KN
Cutting range:	Φ50mm _{max} for telephone cable Φ45mm _{max} for armoured Cu/Al cable
Stroke:	65mm
Length:	630mm
Weight:	7.1kg
Package:	steel case
Weight of case:	3.5kg

CPC-105



TECHNICAL DATA	CPC-105
Cutting force:	60KN
Cutting range:	Φ40mm _{max} for telephone cable Φ28mm _{max} for armoured Cu/Al cable
Stroke:	42mm
Length:	600mm
Weight:	5.6kg
Package:	steel case
Weight of case:	3.3kg

RATCHET MANUAL HYDRAULIC CABLE CUTTER

J13 Ratchet cable cutter



Net weight: about 1.9kg
Size: 345 (extended 514) × 125 × 46mm

Cutting range:

It can cut the steel core aluminum stranded wire below 720mm²



It can cut steel strands below 150mm²



✗ It is strictly forbidden to cut steel and aluminum wires.

Tips: The cutting edge can be used repeatedly.

J25 Ratchet cable cutter



Net weight: about 2.8kg
Size: 565 (extended 745) × 130 × 60mm

Cutting range:

It can cut the steel core aluminum stranded wire below 800mm²



It can cut steel strands below 150mm²



✗ It is strictly forbidden to cut steel and aluminum wires.

Tips: The cutting edge can be used repeatedly.

J30 Ratchet cable cutter



Net weight: about 3.4kg
Size: 406 (extended 514) × 160 × 64mm

Cutting range:

It can cut the steel core aluminum stranded wire below 630mm²



It can cut steel strands below 150mm²



✗ It is strictly forbidden to cut armored cables, steel and aluminum cables, and steel wire ropes.

Tips: The cutting edge can be used repeatedly.

J50 Ratchet cable cutter



Net weight: about 3.2kg
Size: 400 (extended 568) × 158 × 52mm

Cutting range:

It can cut the steel core aluminum stranded wire below 1440mm²



It can cut steel strands below 240mm²



✗ It is strictly forbidden to cut armored cables, steel and aluminum cables, and steel wire ropes.

Tips: The cutting edge can be used repeatedly.

J40 Armoured&Cu/Al ratchet cable cutter



Net weight: about 1.15kg

Size: 346 (extended 568) × 120 × 38mm

Cutting range:

It can cut the armored cable below 300m²



It can cut the Cu/Al cable below 300mm²



✗ It is forbidden to cut steel strand, ACSR and other steel cables.

Tips: The cutting edge can be used repeatedly.

J52 Armoured&Cu/Al ratchet cable cutter



Net weight: about 2.9kg

Size: 397 (extended 568) × 165 × 54mm

Cutting range:

It can cut the armored cable below Φ 50mm



It can cut the Cu/Al cable below Φ 50mm



✗ It is forbidden to cut steel strand, ACSR and other steel cables.

Tips: The cutting edge can be used repeatedly.

J75 Armoured&Cu/Al ratchet cable cutter



Net weight: about 3.6kg

Size: 416 (extended 587) × 200 × 55mm

Cutting range:

It can cut the armored and Cu/Al cable below Φ 75mm²



It can cut 3 × 12 communication cable



✗ It is forbidden to cut steel strand, ACSR and other steel cables.

Tips: The cutting edge can be used repeatedly.

J95 Armoured&Cu/Al ratchet cable cutter



Net weight: about 5.7kg

Size: 416 (extended 587) × 200 × 55mm

Cutting range:

It can cut the copper aluminum core armored cable below 3 × 185mm² or Φ 90mm



✗ It is forbidden to cut steel strand, ACSR and other steel cables.

Tips: The cutting edge can be used repeatedly.

J100 Armoured&Cu/Al ratchet cable cutter



Net weight: about 6.25kg

Size: 482 (extended 655) × 270 × 59mm

Cutting range:

It can cut the copper aluminum core armored cable below 3 × 300mm² or Φ 100mm



✗ It is forbidden to cut steel strand, ACSR and other steel cables.

Tips: The cutting edge can be used repeatedly.

XLJ-100A Ratchet multifunctional cable cutter



Net weight: about 6.3kg

Size: 485(extended 655)×270×59mm

Cutting range:

It can cut off the multi-core Cu/Al armored cable with diameter less than 100mm and 3×300mm²



✗ It is forbidden to cut steel strand, ACSR and other steel cables.

Tips: The cutting edge can be used repeatedly.

XLJ-120A Ratchet multifunctional cable cutter



Net weight: about 10kg

Size: 540(extended 710)×325×80mm

Cutting range:

It can cut the multi-core copper aluminum armored cable with the diameter of 120mm and below



✗ It is forbidden to cut steel strand, ACSR and other steel cables.

Tips: The cutting edge can be used repeatedly.

XLJ-D-300 Ratchet multifunctional cable cutter



Net weight: about 1.1kg

Size: 240×130×47mm

Cutting range:

It can cut the single core Cu/Al cable with a maximum of 300mm² or Φ30mm Cu/Al cable



✗ It is forbidden to cut steel strand, ACSR and other steel cables.

Tips: The cutting edge can be used repeatedly.

XLJ-D-500 Ratchet multifunctional cable cutter



Net weight: about 1.2kg

Size: 240×130×47mm

Cutting range:

It can cut the single core Cu/Al cable with a maximum of 500mm² or Φ50mm Cu/Al cable



✗ It is forbidden to cut steel strand, ACSR and other steel cables.

Tips: The cutting edge can be used repeatedly.

XD-520A Ratchet multifunctional cable cutter



Net weight: about 1.9kg

Size: 310(extended 420)×140×55mm

Cutting range:

Cut 630mm² The following steel-cored aluminum strands

Φ Steel core cable below 32mm

100mm² The following steel strands

Φ Cutting of reinforcement less than 10mm

Φ Cutting of 6-16m steel wire rope

Tips: The cutting edge can be used repeatedly.

ZC-G32A



Cu/Al cable
✓



Armoured cable
✓



ACSR
✓



Steel bar
✗

TECHNICAL DATA

Model No:	ZC-G32A
Cutting range:	Max.100mm ² steel stranded wire Max.600mm ACSR,Max.Φ32mm steel core cable
Length:	350-480mm
Weight:	2.0kg
Package:	canvas bag



ZC-G40A



Cu/Al cable
✓



Armoured cable
✓



ACSR
✓

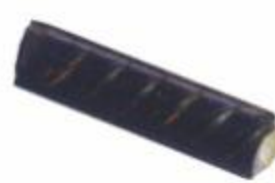

Steel bar
✗

TECHNICAL DATA

Model No:	ZC-G40A
Cutting range:	Max.Φ20mm steel stranded wire Max.Φ36mm Cu/Al cable
Length:	440-630mm
Weight:	3.6kg
Package:	canvas bag



ZC-G40



Cu/Al cable
✓



Armoured cable
✓



ACSR
✓

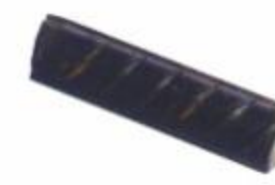

Steel bar
✗

TECHNICAL DATA

Model No:	ZC-G40
Cutting range:	Max.120mm ² steel stranded wire Max.800mm ACSR,Max.Φ36mm steel core cable
Length:	440-630mm
Weight:	3.6kg
Package:	canvas bag



ZC-70A

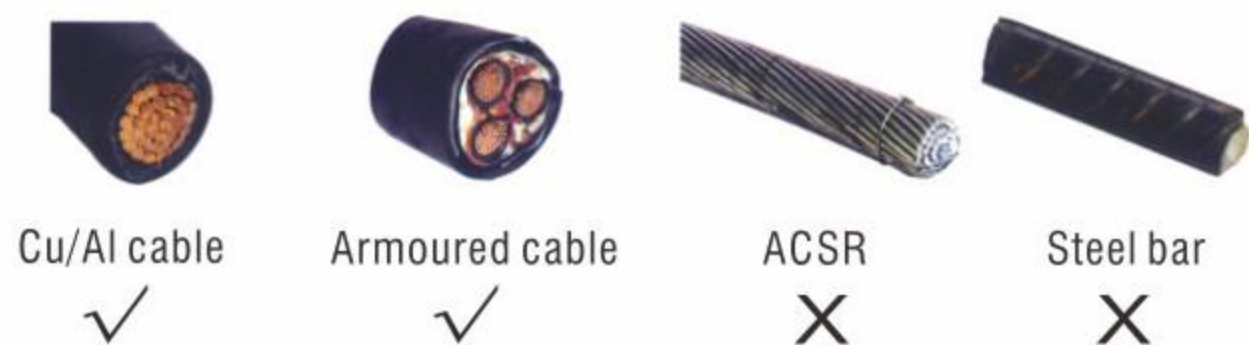

Model No:	ZC-70A
Cutting range:	Max. Φ70mm Cu/Al armoured cable
Length:	380-485mm
Weight:	3.2kg
Package:	canvas bag

ZC-95A

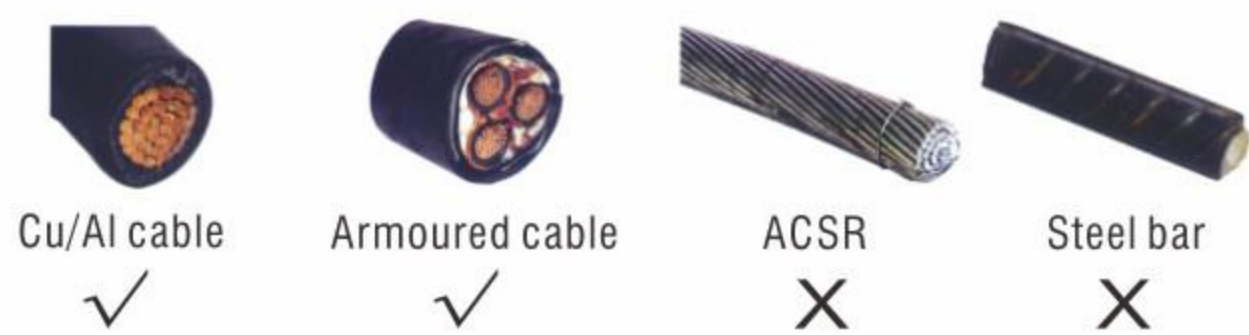

Model No:	ZC-95A
Cutting range:	Max. Φ95mm Cu/Al armoured cable
Length:	530-725mm
Weight:	6.3kg
Package:	canvas bag

ZC-120A

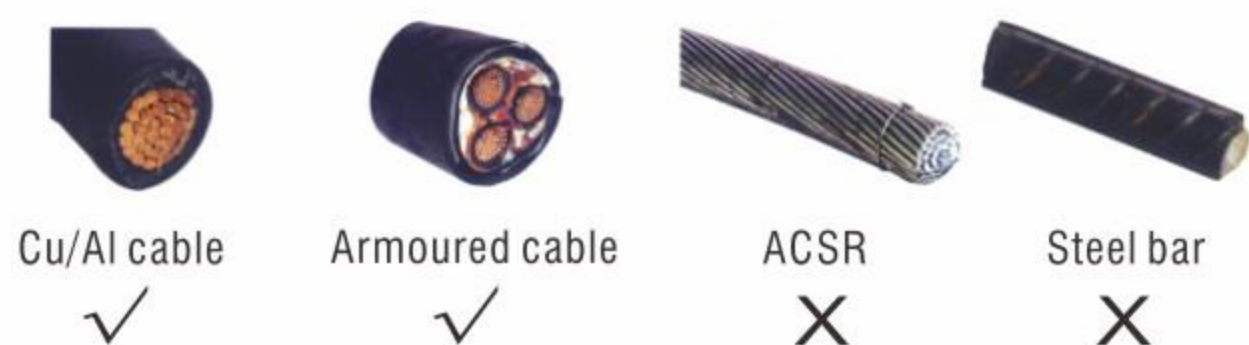

Model No:	ZC-120A
Cutting range:	Max. Φ120mm Cu/Al armoured cable
Length:	555-745mm
Weight:	7.0kg
Package:	canvas bag

ZC-160A

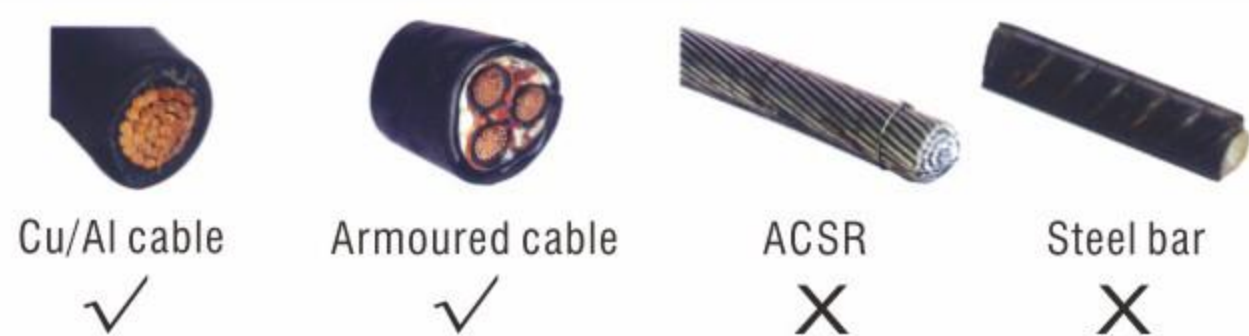

Model No:	ZC-160A
Cutting range:	Max. Φ160mm Cu/Al armoured cable
Length:	760-950mm
Weight:	9.5kg
Package:	canvas bag

The knives are made by forging, long life span and easy to cut.

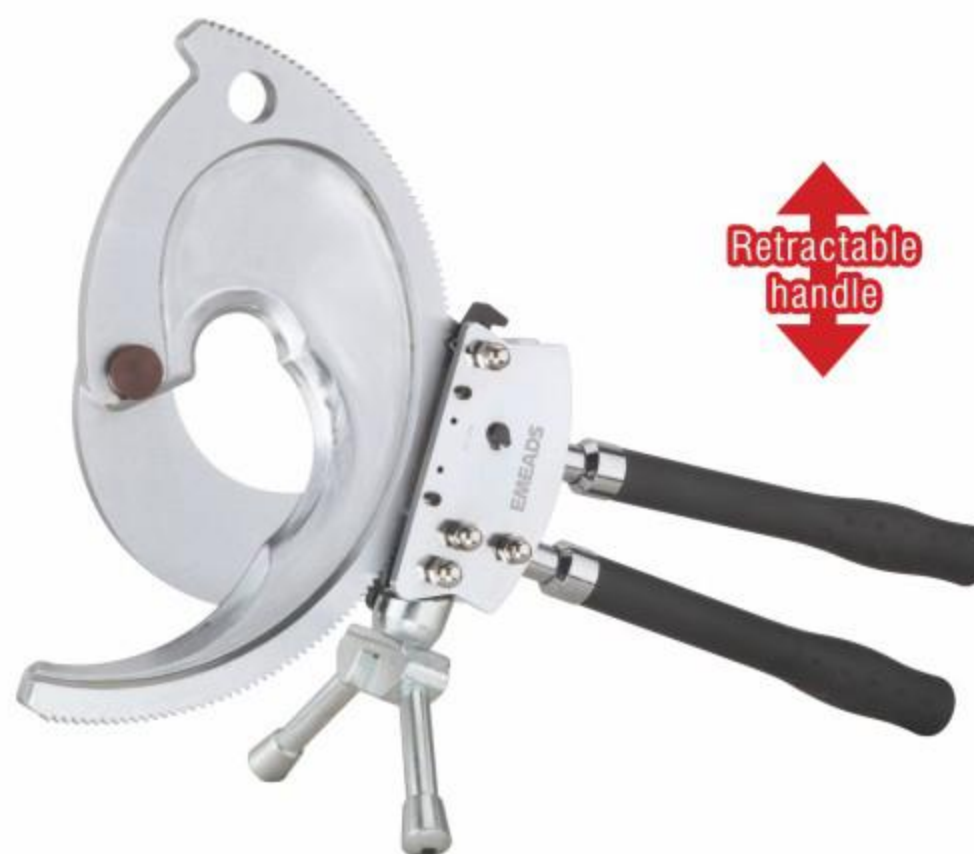
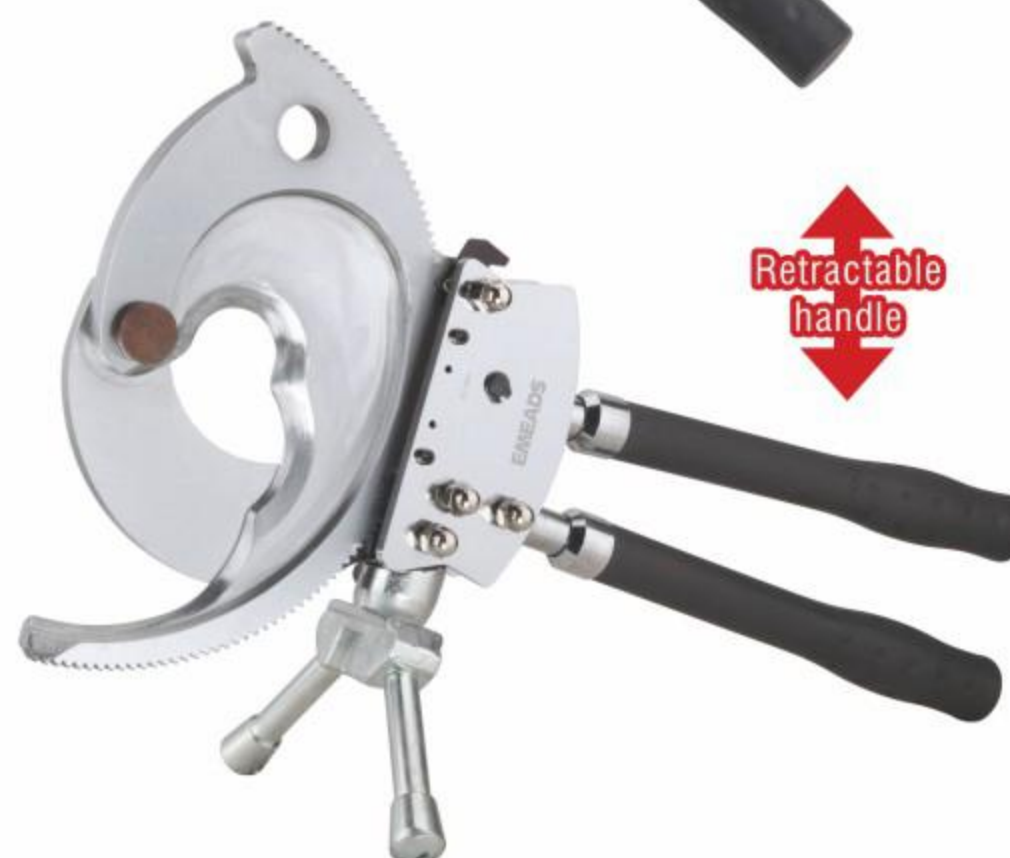

LABOR-SAVING LONG ARM CABLE CUTTER

HS-125/LK-250/LK-500 LABOR-SAVING LONG ARM CABLE CUTTER

- For cutting copper and aluminium conductors as well as multiple stranded cables
- Favourable transmission ratio due to double lever
- Blade: high-grade chrome vanadium electric steel, forged, oil-hardened, replaceable blades
- Handles material: Steel

For Cu/Al conductor and communication cable only.



HS-125

TOOL PARAMETERS	
Cutting capacity	125 mm ²
Length	385mm
Weight (Net weight/Gross weight)	0.71/0.81Kg



LK-250

TOOL PARAMETERS	
Cutting capacity	250mm ²
Length	560mm
Weight (Net weight/Gross weight)	1.66/1.86Kg



LK-500

TOOL PARAMETERS	
Cutting capacity	500 mm ²
Length	745mm
Weight (Net weight/Gross weight)	4.13/4.47Kg

CABLE STRIPPER

PG-5 CABLE STRIPPER

- For removing all layers of insulation on cables with diameters of over 25mm
- Suitable for longitudinal and circular cutting, Cutting depth can be adjusted from 0-5mm
- Replaceable blade (both sides can be used)

Application

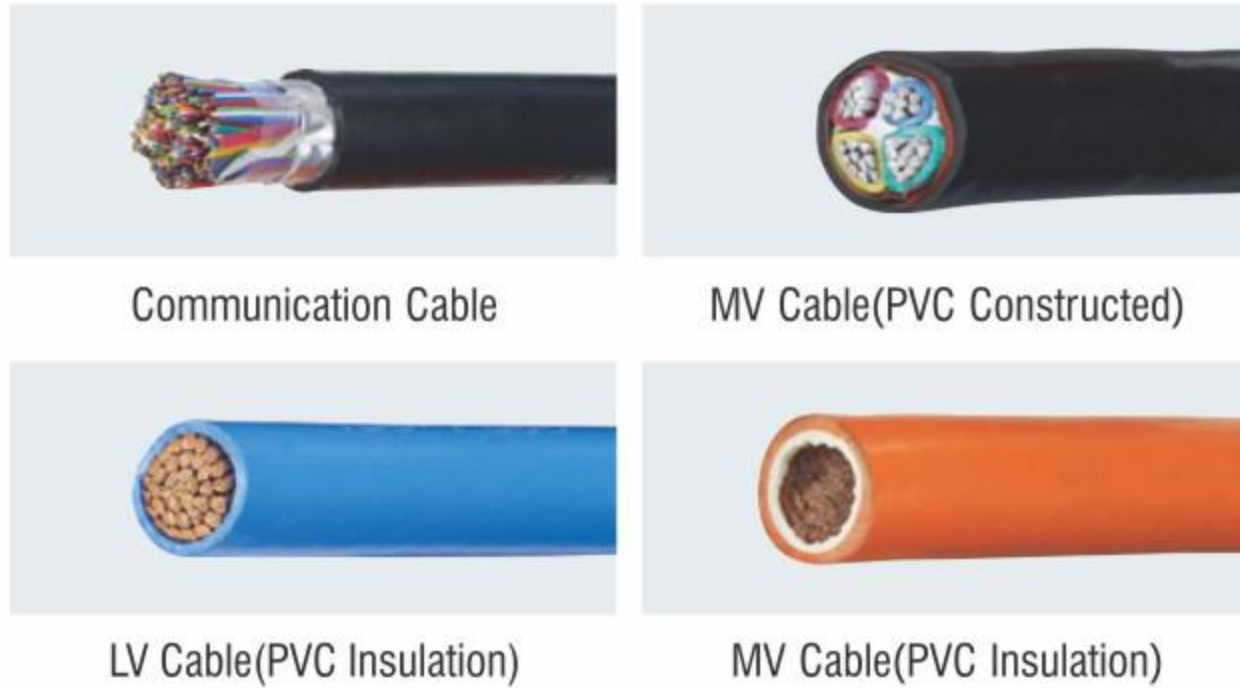

Changing the blade:
By removing the adjusting screw, the double-ended blade can be changed.

TOOL PARAMETERS

Stripping capacity	≥Φ 25 mm
Length	155 mm
Weight(Net weight/Gross weight)	0.2/0.24Kg



SK-40/SK-50 CABLE STRIPPER

- Range of use: The tool is applicable for stripping the external insulation layer of cable less than 35kV.
- Operating instruction: The tool comprises of the base, the moving seat and the frame.
- The blade can be held in the moving upper part by the screw. And the repairing blade can be fixed on the two planes by the attached inner hexagon spanner easily.
- When the tool turns clockwise along cable, it can move automatically with the direction of cable.
- It can be adjusted by the adjusting screw.

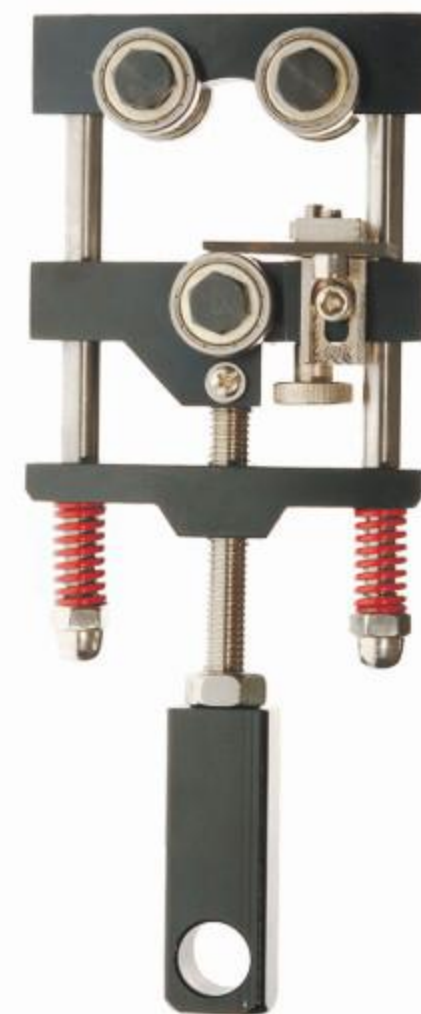
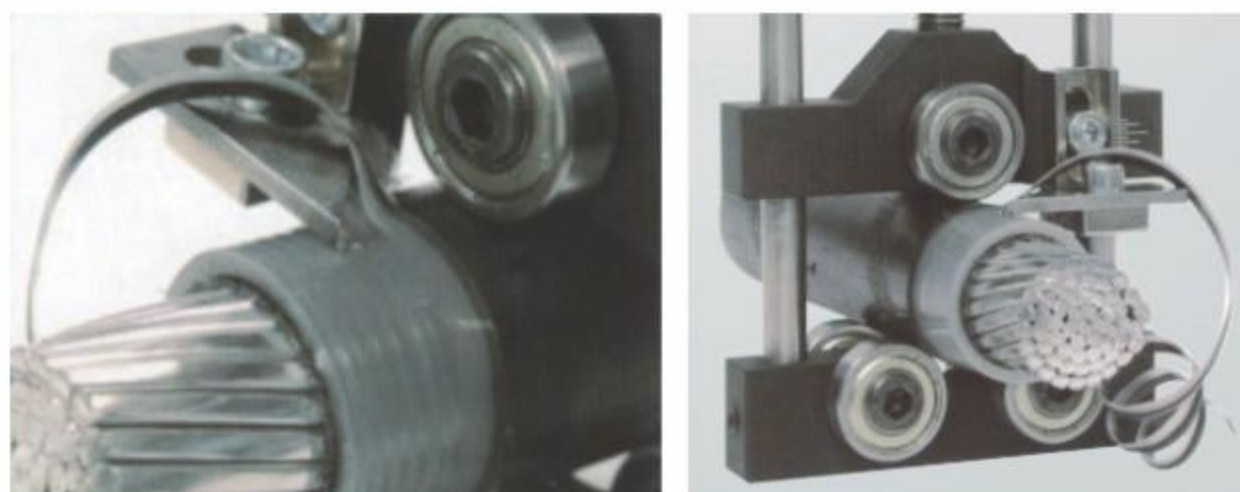

Package:
Plastic case

TOOL PARAMETERS

	SK-40	SK-50
Stripping capacity	Φ20-40 mm	Φ20-50 mm
Length	250 mm	250 mm
Weight (Net weight/Gross weight)	1.06/1.15Kg	1.06/1.15Kg

BX-30 CABLE STRIPPER

- Stripping of the main insulating layer at the end and middle section of insulated wire or power cable core.
- The cutting thickness can be adjusted as required.

TOOL PARAMETERS

Stripping capacity	Φ15-30 mm
Size	280×75×50 mm
Weight(Net weight/Gross weight)	0.68/0.83Kg



The knives cannot touch the metal cable cores when stripping knives can be sharpened or replaced.

BX-40 CABLE STRIPPER

- Stripping of the main insulation layer at the end of the insulated wire or power cable core



TOOL PARAMETERS

Stripping capacity	Φ20-40 mm
Size	245×87×55mm
Weight(Net weight/Gross weight)	0.8Kg

BX-90 CABLE STRIPPER

- Stripping and sharpening of high-voltage cable ends



TOOL PARAMETERS

Stripping capacity	Φ40-90 mm
Size	490×140×75mm
Weight(Net weight/Gross weight)	2.5Kg

KBX-45 CABLE STRIPPER

- Cable insulation stripping



TOOL PARAMETERS

Stripping capacity	Φ45 mm
Size	245×80×90mm
Weight(Net weight/Gross weight)	0.8Kg

KBX-65 CABLE STRIPPER

- Cable insulation stripping

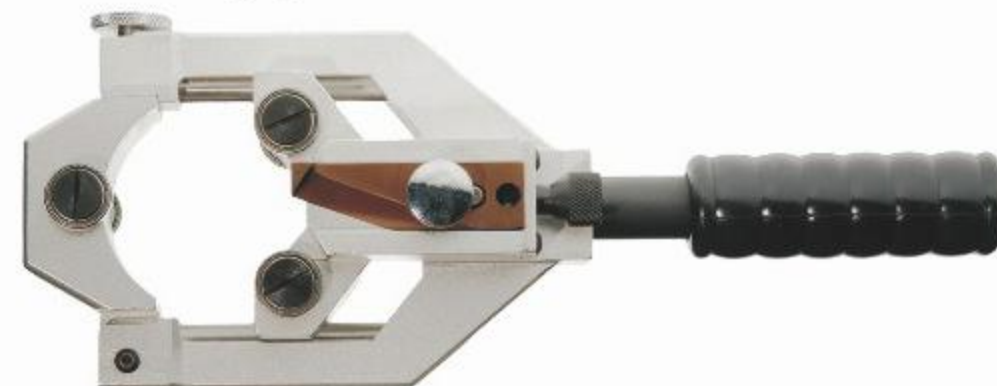

TOOL PARAMETERS

Stripping capacity	Φ65 mm
Size	295×125×70mm
Weight(Net weight/Gross weight)	1.4Kg

LBX/CX121 CABLE STRIPPER

- Stripping of the main insulation layer of cables with a thickness of ≤4.5



TOOL PARAMETERS

Stripping capacity	Φ30 mm
Size	220×95×75mm
Weight(Net weight/Gross weight)	0.69/0.93Kg

SBX/CX119 CABLE STRIPPER

- Stripping off the insulation of overhead insulated cables



TOOL PARAMETERS

Stripping capacity	35-300mm ²
Size	240×180×90mm
Weight(Net weight/Gross weight)	0.5Kg

SC-85 / SC-105

FEATURES:

- Split hydraulic cable cutter can work with hydraulic handpump or electric hydraulic pump, it is suit for big size of telephone cables or armoured Cu/Al cables..



TECHNICAL DATA:

Model No:	SC-85	SC-105
Cutting force:	60KN	120KN
Cutting range:	Φ100mm _{max} (for telephone cable) Φ75mm _{max} (for armoured Cu/Al cable)	Φ100mm _{max} (for telephone cable) Φ75mm _{max} (for armoured Cu/Al cable)
Stroke:	90mm	110mm
Length:	approx.480mm	approx.505mm
Weight:	approx.7.90kg	approx.8.40kg
Package:	Plastic box	Plastic box

NOTE: it can use with any hydraulic hand pump or electrical pump

CC-50B

FEATURES:

- Split hydraulic cable cutter can work with hydraulic handpump or electric hydraulic pump, it is suit for big size of telephone cables or armoured Cu/Al cables..



TECHNICAL DATA:

Model No:	CC-50B
Cutting force:	116KN
Cutting range:	Φ50mm _{max} (for telephone cable) Φ45mm _{max} (for armoured Cu/Alu cable)
Stroke:	24mm
Length:	approx.340mm
Weight:	approx.6.20kg
Package:	Plastic box

NOTE: it can use with any hydraulic hand pump or electrical pump

SPLIT-TYPE CABLE CUTTER HEAD

SC-40

FEATURES:

- Split hydraulic cable cutter can work with hydraulic handpump or electric hydraulic pump.
- It is suit for big size of ACSR cable or steel wire strand.

TECHNICAL DATA:

Model No:	SC-40
Cutting force:	60KN
Cutting range:	Φ40mm _{max} Armoured and Cu/Al cable/ACSR stranded wire
Stroke:	42mm
Length:	approx.320mm
Weight:	approx.3.80kg
Package:	Plastic box

NOTE: it can use with any hydraulic hand pump or electrical pump

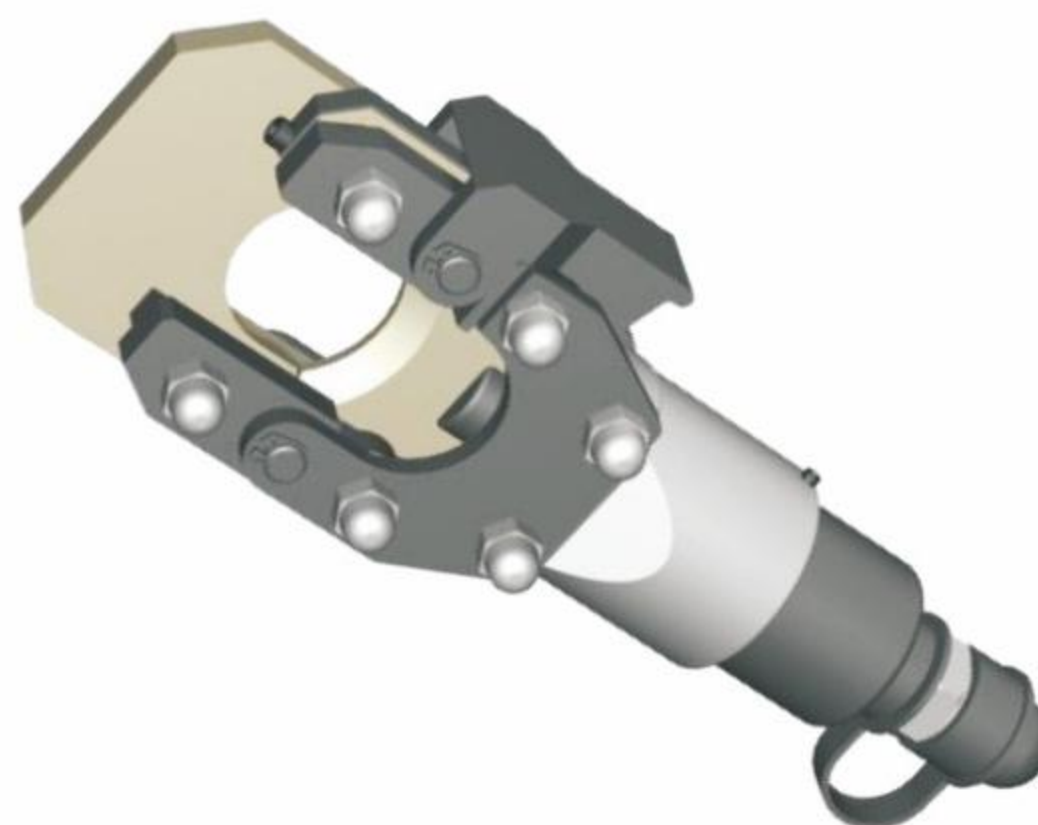

SC-55

FEATURES:

- Flip top cutting head rotates 360°.
- New two stage hydraulic to reduce cutting cycle,automatic release pressure when cut is complete.
- Manual release in case of need.

TECHNICAL DATA:

Model No:	SC-55
Cutting force:	120KN
Cutting range:	Φ50mm _{max} Armoured and Cu/Al cable/ACSR stranded wire
Stroke:	50mm
Length:	approx.355mm
Weight:	approx.4.20kg
Package:	Plastic box

NOTE: it can use with any hydraulic hand pump or electrical pump



(15T) SC-85C / 105C / 120C

Model	(15T)SC-85C	(15T)SC-105C	(15T)SC-120C
Cutting force	120KN	150KN	150KN
Stroke	70mm	105mm	120mm
Cutting times	40-70次 (saturation voltage)	40-70次 (saturation voltage)	40-70次 (saturation voltage)
Cutting range	Φ70mm _{max} (Armored and copper aluminum cables)	Φ105mm _{max} (Armored and copper aluminum cables)	Φ120mm _{max} (Armored and copper aluminum cables)
Net weight	4kg	4.5kg	5kg
Packing	The plastic box	The plastic box	The plastic box

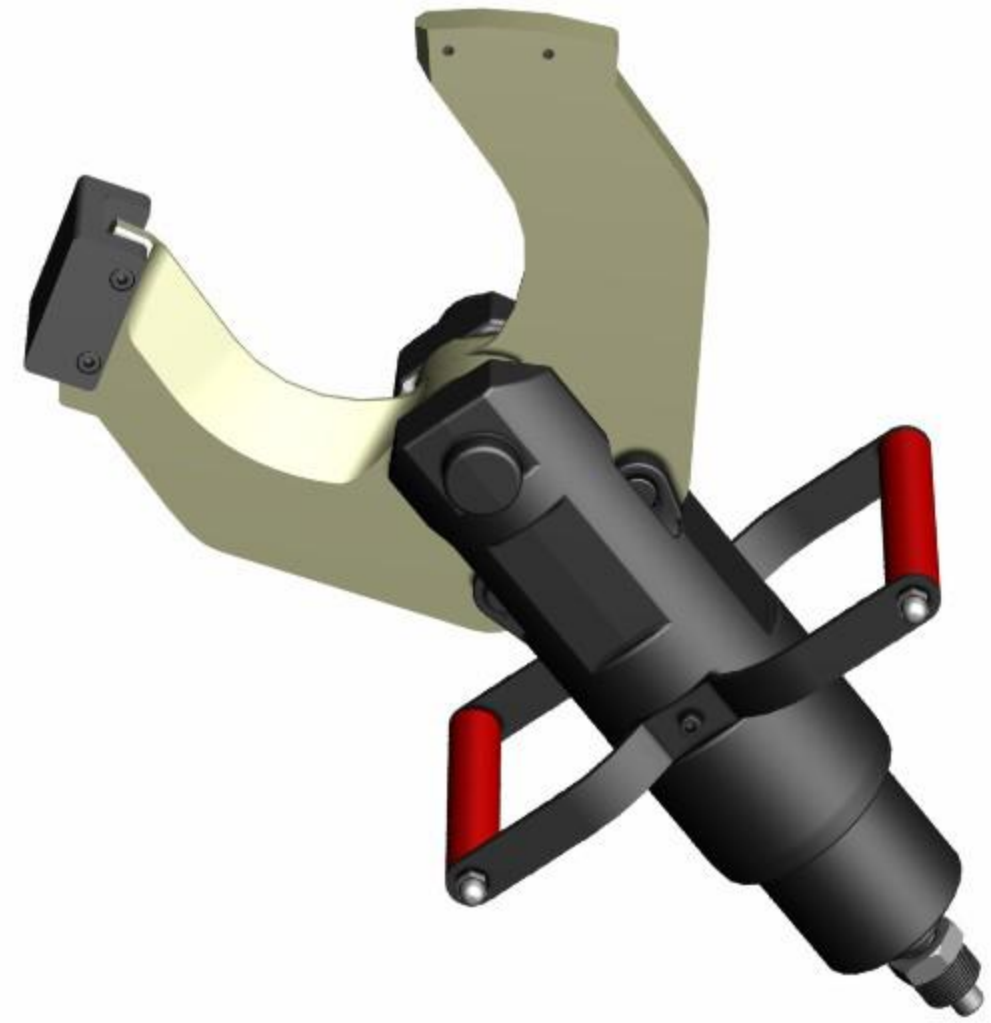

FEATURES:

- Opening C type cutting head.
- Hydraulic quick coupler connect with the pump for working.
- Guide pad design avoid the blade dislocation during cutting procession.

(25T) SC-105C / 120C / 135C

Model	(25T)SC-105C	(25T)SC-120C	(25T)SC-135C
Cutting force	200KN	200KN	200KN
Stroke	105mm	120mm	135mm
Cutting times	40-70次 (saturation voltage)	40-70次 (saturation voltage)	40-70次 (saturation voltage)
Cutting range	Φ105mm _{max} (Armored and copper aluminum cables)	Φ120mm _{max} (Armored and copper aluminum cables)	Φ135mm _{max} (Armored and copper aluminum cables)
Net weight	5.5kg	6kg	7kg
Packing	The plastic box	The plastic box	The plastic box



SPILT-TYPE SPECIAL FOR IRON PIPE CUTTER HEAD

Special for iron pipe

(15T) SC-105CTG / 120CTG

Model	(15T)SC-105CTG	(15T)SC-120CTG
Cutting force	150KN	150KN
Stroke	62mm	62mm
Cutting times	70次 (saturation voltage)	50次 (saturation voltage)
Cutting range	δ3mm Φ60mm _{max}	δ3mm Φ80mm _{max}
Net weight	4.5kg	5kg
Packing	The plastic box	The plastic box

FEATURES:

- Opening C type cutting head.
- Hydraulic quick coupler connect with the pump for working.
- Guide pad design avoid the blade dislocation during cutting procession.

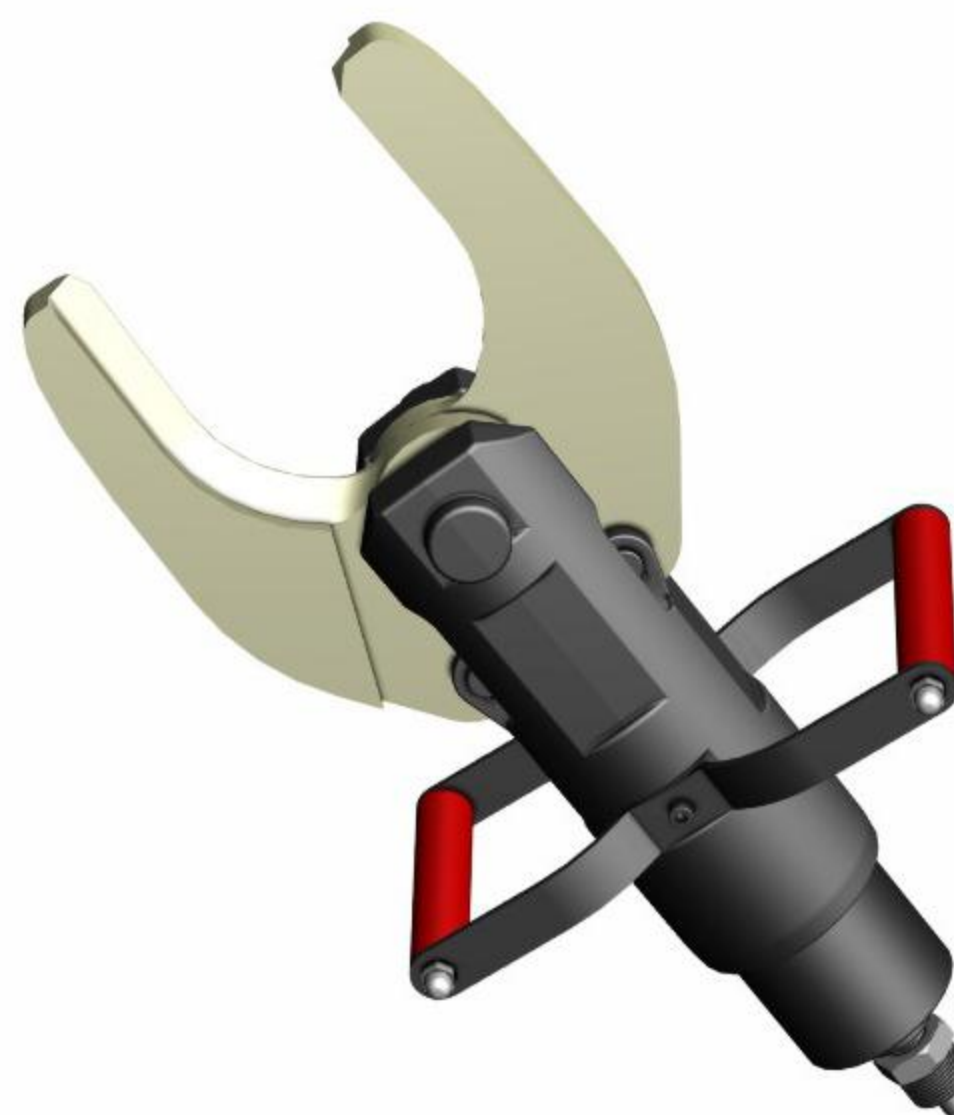

Special for iron pipe

(25T) SC-105CTG / 120CTG / 135CTG

Model	(25T)SC-105CTG	(25T)SC-120CTG	(25T)SC-135CTG
Cutting force	200KN	200KN	200KN
Stroke	62mm	62mm	62mm
Cutting times	70次 (saturation voltage)	50次 (saturation voltage)	40次 (saturation voltage)
Cutting range	δ4mm Φ60mm _{max}	δ4mm Φ80mm _{max}	δ4mm Φ100mm _{max}
Net weight	5.5kg	6kg	7kg
Packing	The plastic box	The plastic box	The plastic box

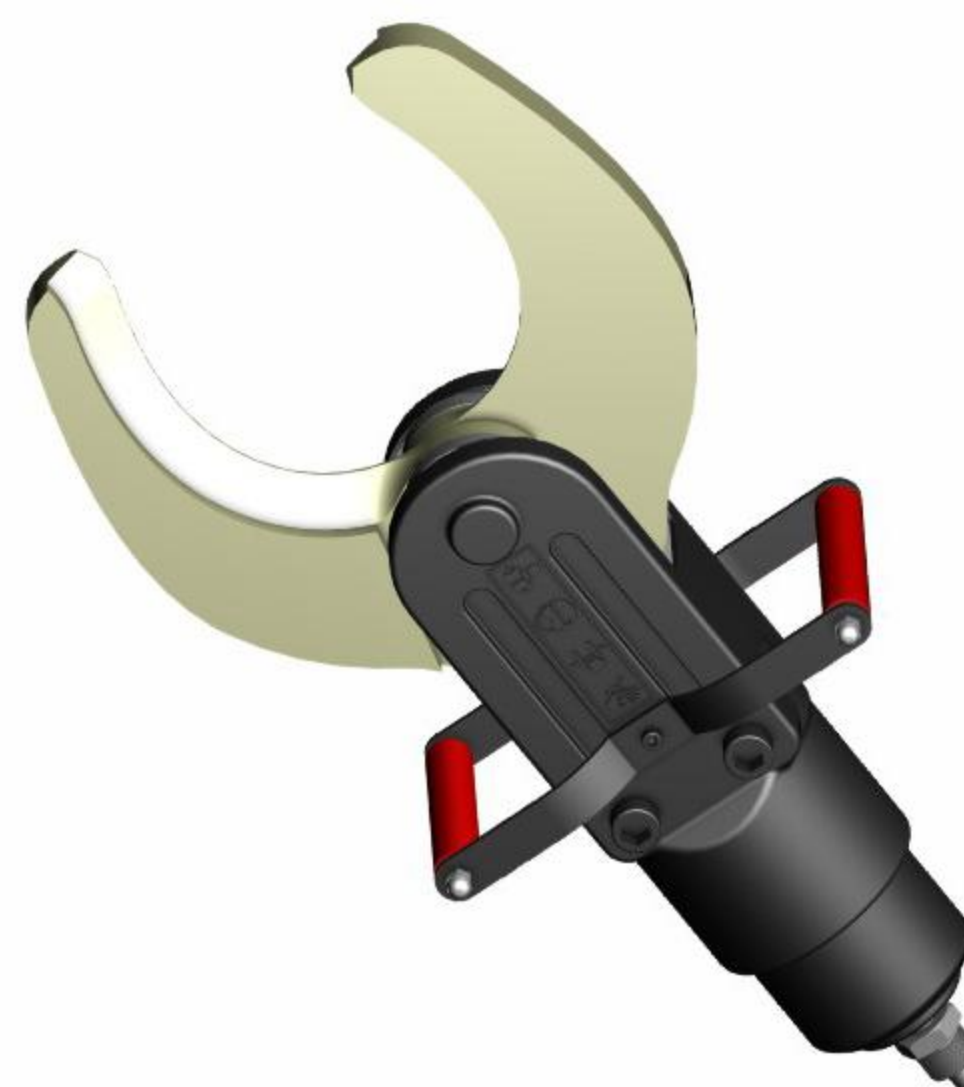

EBS-60UNV (continuous crimping type)



EB-60UNV (conventional type)



DES-60UNV (Brushless continuous crimping type)



DE-60UNV (Brushless conventional type)



TECHNICAL DATA

Crimping force:	60KN
Stroke:	42mm
Cutting times:	70times (Per saturation voltage)
Cutting range:	Φ40mm _{max} (Armoured and Cu/Al cable)
Crimping times:	160times (Per saturation voltage)
Crimping range:	16-300mm ²
Punching times:	100times (Per saturation voltage)
Punching range:	Φ22.5-Φ61.5mm
Round punch Max.:	61.5mm
Working cycle:	3-15s
Voltage/capacity:	18V/4.0Ah
Net weight:	4.8kg
Charging time:	2 hours
Package:	Plastic box

ACCESSORIES

Crimping dies:	4, 6, 10, 16, 25, 35, 50, 70, 95, 120, 150, 185, 240, 300mm ²		
Punching dies:	22.5, 28.3, 34.6, 43.2, 49.6, 61.5mm		
Adapter for crimping:	1pc	Spacer:	1pc
Adapter for punching:	1pc	Battery:	2pcs
Pull pin 3/4", 16UN Draw stud:	1pc	Charger:	1pc
Pull pin 7/16", 20UN Draw stud:	1pc		



CHARGING TYPE MULTI-FUNCTIONAL HYDRAULIC TOOL (crimping/cutting/punching)

EMEADS[®]
ZHEJIANG EMEADS TOOLS CO.,LTD

GES-60UNV / GE-60UNV (Mini continuous crimping type)

TECHNICAL DATA

Crimping force:	60KN
Stroke:	42mm
Cutting times:	70times (Per saturation voltage)
Cutting range:	Φ40mm _{max} (Armoured and Cu/Al cable)
Crimping times:	160times (Per saturation voltage)
Crimping range:	16-300mm ²
Punching times:	100times (Per saturation voltage)
Punching range:	Φ22.5-Φ61.5mm
Round punch Max.:	61.5mm
Working cycle:	3-15s
Voltage/capacity:	18V/4.0Ah
Net weight:	4.8kg
Charging time:	2 hours
Package:	Plastic box

ACCESSORIES

Crimping dies:	4, 6, 10, 16, 25, 35, 50, 70, 95, 120, 150, 185, 240, 300mm ²
Punching dies:	22.5, 28.3, 34.6, 43.2, 49.6, 61.5mm
Adapter for crimping:	1pc
Adapter for punching:	1pc
Pull pin 3/4", 16UN Draw stud:	1pc
Pull pin 7/16", 20UN Draw stud:	1pc
Spacer:	1pc
Battery:	2pcs
Charger:	1pc



MANUAL TYPE MULTI-FUNCTIONAL HYDRAULIC TOOL (crimping/cutting/punching)

HT-60UNV (Manual type)

TECHNICAL DATA

Crimping force:	60KN
Stroke:	42mm
Crimping range:	Cu16-300mm ² Al10-240mm ²
Cutting range:	Φ40mm _{max} (Armoured and Cu/Al cable)
Punching range:	Φ22.5-61.5mm in the 3.5mm mild steel
Length:	540mm
Weight:	3.5kg
Package:	steel case

ACCESSORIES

Crimping dies:	16, 25, 35, 50, 70, 95, 120, 150, 185, 240, 300mm ²
Punching dies:	22.5, 28.3, 34.6, 43.2, 49.6, 61.5mm
Adapter for crimping:	1pc
Adapter for punching:	1pc
Pull pin 3/4", 16UN Draw stud:	1pc
Pull pin 3/8", 24UN Draw stud:	1pc
Spacer:	1pc



MULTI FUNCTIONAL

CRIMPING, CUTTING AND PUNCHING WITH ONE SINGLE TOOL

<p>Adapter</p> 	<p>Application: For crimping</p> <p>Cu compression cable lugs and compression joints 16-300mm² Al compression cable lugs and compression joints 10-240mm²</p>
<p>Blade</p> 	<p>Application: For cutting</p> <p>Φ40mm Cu/Al cable and Armored cable</p>
<p>Adapter</p> 	<p>Application: For punching</p> <p>22.5-61.5mm Round dies. for 3.5 mm mild steel punching</p>



FEATURES



The hydraulic unit incorporates an automatic retraction which returns the piston into its starting position when the maximum operating pressure is reached.



A manual retraction allows the user to return the piston into the starting position in case of an incorrect crimp. The unit is equipped with a special brake when stops the forward motion of the piston & die when the trigger is released.



The unit is equipped with a double piston pump which is characterised by a rapid approach of the dies forwards the connector and a slow working motion.



The head can be smoothly turned by 350° around the longitudinal axis in order to gain better access to tight corners and other difficult working areas.



Li-ion batteries do neither have a memory effect nor self discharge. Even after long periods of non operation the tool is always ready to operate. In addition we see a lower power weight ratio with 50% more capacity and shorter charging cycles compare to NiMH batteries.



A Temperature sensor makes the tool stop working automatically when the temperature over 60C° under long time working, the fault signal sounds, it means the tool can't continue work until the temperature reduced to the normal.

MULTIFUNCTIONAL OPTIONAL CLAMP HEAD



EF-400 Crimping pliers

TECHNICAL DATA	
Crimping force:	120KN
Stroke:	42mm
Crimping times:	120times (Cu150mm ²) (Per saturation voltage)
Crimping cycle:	6-18s Depend on the size of cable
Net weight:	3.0kg



EF-400U Crimping pliers

TECHNICAL DATA	
Crimping force:	120KN
Stroke:	20mm
Crimping times:	120times (Cu150mm ²) (Per saturation voltage)
Crimping cycle:	6-18s Depend on the size of cable
Net weight:	1.5kg



EF-40 Cable shear

TECHNICAL DATA	
Cutting force:	60KN/120KN (120KN optional tong head)
Stroke:	40mm
Cutting times:	130times (Per saturation voltage)
Cutting range:	Φ35mm _{max} ACSR stranded wire
Net weight:	2kg



EF-50 Cable shear

TECHNICAL DATA	
Cutting force:	120KN
Stroke:	50mm
Cutting times:	70times (Per saturation voltage)
Cutting range:	Φ40mm _{max} Armoured and Cu/Al cable
Net weight:	2.5kg



EF-85C Cable shear

TECHNICAL DATA	
Cutting force:	120KN
Stroke:	85mm
Cutting times:	130times (Per saturation voltage)
Cutting range:	Φ70mm _{max} Armoured and Cu/Al cable
Net weight:	6.0kg



EF-120C Cable shear

TECHNICAL DATA	
Cutting force:	200KN
Stroke:	85mm
Cutting times:	130times (Per saturation voltage)
Cutting range:	Φ110mm _{max} Armoured and Cu/Al cable
Net weight:	6.0kg



EF-1220H Punch

TECHNICAL DATA	
Max.output:	120KN
Stroke:	18mm
Punching times:	250times (Per saturation voltage)
Net weight:	5.0kg
Punching range:	Φ10.5, 13.5, 17.5, 20.5mm



EF-2436 Nut cutter

TECHNICAL DATA	
Max.output:	120KN
Stroke:	18mm
Cutting times: (per saturation voltage)	250times Depend on M12-4.8 grade nut
Cutting range:	13-24mm
Net weight:	1.5kg
Splitting range:	M8-M24